

# 64.5" LCD Display Monitor

MODEL

# MDT65IS (BV928)

## USER'S MANUAL

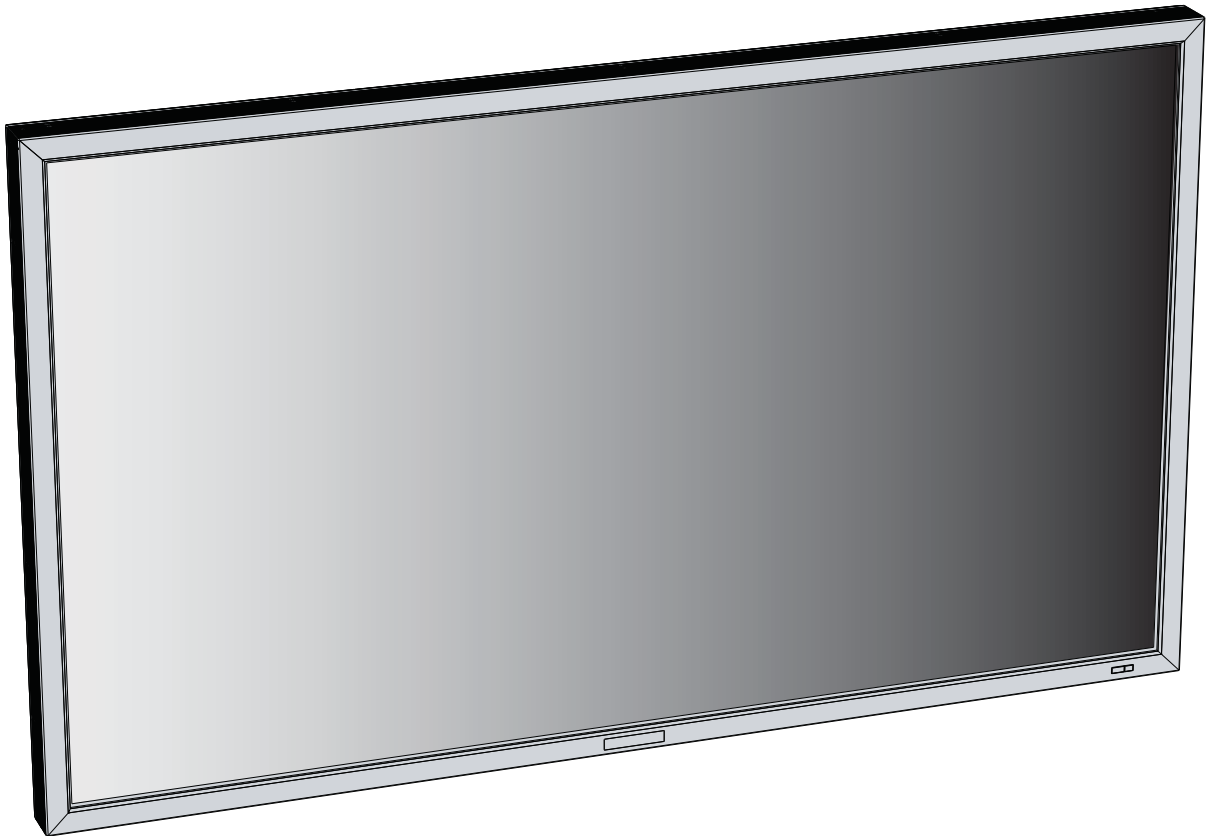



# English

---



# Index

Features .....	English-2
Important Information .....	English-3
Declaration .....	English-5
Safety Precautions, Maintenance & Recommended Use .....	English-6
Contents .....	English-7
Parts Name and Functions .....	English-8
Buttons, Switch, and Indicator .....	English-8
Connectors and Terminals .....	English-9
Wireless Remote Control .....	English-10
How to Use the Wireless Remote Control .....	English-11
CAT5 Tx BOX .....	English-12
Preparation for use .....	English-13
Flow of preparation .....	English-13
[P-1] Preparation for installation .....	English-14
Determine the installation location .....	English-14
Ventilation requirements for enclosure mounting .....	English-14
[P-2] Installing the monitor .....	English-15
Using the wall mount or ceiling mount .....	English-15
Using the monitor without the bezel .....	English-15
Installing in the portrait position .....	English-16
[P-3] Installing the optional speakers .....	English-17
[P-4] Connection procedure .....	English-18
Wiring diagram .....	English-18
Prevention of disconnection of HDMI cable .....	English-18
Connecting with a computer (analog connection) .....	English-19
Connecting with a computer (digital connection) .....	English-20
Connecting a video device (component video/HDMI device) .....	English-21
Connecting a video device (composite video/S video device)/stereo amplifier .....	English-22
[P-5] Connecting CAT5 .....	English-23
CAT5 for long-distance connection or multiple-monitor connection.....	English-23
[P-6] Connecting RS-232C .....	English-25
Monitor control via RS-232C .....	English-25
[P-7] Connecting LAN .....	English-26
Monitor connection using LAN .....	English-26
[P-8] Connecting the power cord to the monitor .....	English-27
Connecting the power source .....	English-27
How to Use .....	English-28
Flow of How to Using .....	English-28
[U-1] Turning on all the connected devices .....	English-29
Turning on external devices .....	English-29
Turning on the monitor .....	English-29
Power Management Function .....	English-29
[U-2] Selecting the video input .....	English-30
[U-3] Controlling the external devices .....	English-31
[U-4] Selecting the OSD language .....	English-31
[U-5] Auto-setup .....	English-32
[U-6] Selecting the picture mode .....	English-32
[U-7] Screen adjustment .....	English-33
[U-8] Picture adjustment .....	English-33
[U-9] Volume control .....	English-34
[U-10] Schedule setting .....	English-34
How to set up schedule .....	English-35
[U-11] Remote control .....	English-36
RS-232C/RS-485 Remote control .....	English-36
LAN Remote control .....	English-38
Configuration and basic operation of OSD screen .....	English-39
Configuration of OSD screen .....	English-39
Basic operation of OSD .....	English-40
OSD screen functions .....	English-41
Other functions .....	English-51
Picture size .....	English-51
Picture mode .....	English-51
Audio input change .....	English-51
OSD information .....	English-51
Control Lock mode .....	English-51
Supplemental information of the auto brightness function .....	English-52
PIP, POP function .....	English-53
Remote control numbering function .....	English-54
Troubleshooting .....	English-55
Specifications .....	English-56
Pin Assignment .....	English-57

# Features

## Engineered Specially for Public Display Use with High Durability and High-level Specifications

### **Panel Designed for Heavy Use**

**Page 56**

Highly durable LCD panel for commercial use. Able to keep displaying crisp, vivid images and endures harsh environments of various public places such as airports and stations.

### **High Brightness, High Contrast**

**Page 56**

High brightness of 700 cd/m<sup>2</sup> and high contrast ratio of 2500:1. Offers brightness as high as 700 cd/m<sup>2</sup> for easy viewing in well-lit public places. A high contrast ratio of 2500:1 delivers sharp images with clear black and white colors, allowing viewers to read displayed information even from a distance.

## Enhanced Display Functionality for Various Commercial Use/Support for System Configuration Suitable for Diversified Applications

### **6-axis Color Adjustment Function**

**Page 41**

6-axis color adjustment function for adjusting specific colors only.

You can adjust total six colors of red, green, blue and three medium colors independently to reproduce skin tones and colors of company or brand logos accurately in signage applications.

### **Digital Zoom**

**Page 43**

Zoom mode for expanding 4:3 image to 16:9. Various zoom modes are provided and it is possible to expand 4:3 aspect ratio images to 16:9. In addition, you can select the dynamic display mode to display naturally widened images with different zooming rates around the screen center and screen edges. You can also optimally change the image size diagonally, horizontally, and vertically.

### **Tiling Capability with Frame compensation**

**Page 49**

Up to 25 panels (5 wide x 5 high) can be combined to create a single large image (i.e., video wall) or other high-impact signage. A frame compensation function is incorporated to compensate the width of panel bezels so that images are displayed with the utmost accuracy.

### **PiP, PoP and Side-by-side**

**Pages 10, 45, and 53**

Picture-in-Picture and Picture-out-of-Picture are available when you want to display video content from a video input source in the sub picture and display the PC input source in the main picture, and vice versa.

The native resolution as high as 1920 x 1080 can display these two input sources in the Side-by-side mode, ideal for broadcasting and video-conferencing applications.

## Equipped with CAT5 Analog Signal Transmission Function/ Supports Max. 150-meter Long Cable

### **CAT5 Video Connection**

**Page 12 and 23**

Transmitting analog video signal and control signal over a single CAT5 cable.

You can transmit analog RGB video signal and display control signal over a single CAT5 cable. Long-distance transmission up to 150 meters allows flexible installation of the monitors and the personal computer.

### **Daisy-chain Connection (CAT5)**

**Page 23**

Linking up to 5 monitors.

You can connect up to 5 monitors in a daisy-chain configuration using CAT5 cable (max. 200 meters). The monitors can be installed away from each other depending on the usage.

## Variable Management Functions Supporting Efficient Operation and Management

### **Programmable Scheduling Function**

**Page 34 and 48**

The monitor's operating schedule can be programmed for up to seven different scheduled time intervals by time, day of the week and input port. This allows video content from different inputs to be displayed on certain monitors within the same installation according to the schedule, and extends the monitor's life and saves the power by turning it off during those hours or days it is not in use.

### **Screen-saver Functions**

**Page 46**

To reduce image persistence and maximize the panel life in demanding signage applications, this product is equipped with four screen-saver functions.

- GAMMA
- COOLING FAN
- BRIGHTNESS
- MOTION

### **Power-on Delay**

**Page 50**

For installations employing numerous monitors, the power-on delay function can power up the monitors sequentially with delay between 2-50 seconds after the power is applied. Using this function can prevent inrush current problems and reduce the overall electrical load requirements when a single power supply is used.

## Brightness Compensation by the Ambient Light Sensors for Enhanced Visibility and Lower Power Consumption

### **Ambient Light Sensors (Brightness sensors)**

**Page 8 and 52**

Automatic screen brightness adjustment for enhanced visibility and lower power consumption.

The ambient light sensors on the front and rear of the monitor detect not only the light reflected on the front but also that on the rear to automatically obtain optimum brightness. Besides, the monitor adjusts its screen brightness according to the brightness of the displayed images. The screen is always easy to view in spite of brightness variation in the daytime and nighttime.

## Others

### **DisplayPort**

**Page 9 and 18**

DisplayPort-compliant terminal is provided.

The monitor is equipped with a terminal supporting DisplayPort, the next generation digital interface standard. You can transmit video signals over a single cable of max. 15 meters long.

### **Speakers**

**Page 9 and 17**

Special optional speakers can be installed.

The monitor is equipped with 7 W + 7 W speaker output connectors, through which voice messages, etc. are output clearly.

### **Remote Control**

**Page 10 and 11**

Special wireless remote control supports major operations and settings.

The special wireless remote control is supplied for major controls such as power-on/off, video source switching, and various settings.

### **Closed Caption**

**Page 50**

You can display captions.

When closed-caption video signals are input, you can select to display or hide the captions on the screen.

This monitor is compliant with EIA-608-A.

# Important Information

---

---

## DECLARATION OF CONFORMITY

---

---

This device complies with Part 15 of FCC Rules. Operation is subject to the following two conditions. (1) This device may not cause harmful interference, and (2) this device must accept any interference received, including interference that may cause undesired operation.

**U.S. Responsible Party: Mitsubishi Digital Electronics America, Inc.**

**Address: 9351 Jeronimo Road,  
Irvine, California 92618 U.S.A.**

**Tel. No.: +1 - (949) 465-6000**

Type of Product: Computer Monitor

Equipment Classification: Class B Peripheral

Model: MDT651S (BV928)



*We hereby declare that the equipment specified above  
conforms to the technical standards as specified in the FCC Rules.*

---

---

Windows is a registered trademark of Microsoft Corporation.

HDMI, the HDMI logo, and High-Definition Multimedia Interface are trademarks or registered trademarks of HDMI Licensing LLC in the United States and other countries.

The DisplayPort Icon is a trademark of the Video Electronics Standards Association, registered in the U.S. and other countries.

All other brands and product names are trademarks or registered trademarks of their respective owners.

### Canadian Department of Communications Compliance Statement

DOC: This Class B digital apparatus meets all requirements of the Canadian Interference-Causing Equipment Regulations.

C-UL: Bears the C-UL Mark and is in compliance with Canadian Safety Regulations according to CAN/CSA C22.2 No. 60950-1.

### FCC Information

1. Use the attached specified cables with this equipment so as not to interfere with radio and television reception.
  - (1) The power supply cord you use must have been approved by and comply with the safety standards of U.S.A.,
  - (2) Please use the supplied shielded video signal cable. Use of other cables and adapters may cause interference with radio and television reception.
2. This equipment has been tested and found to comply with the limits for a Class B digital device, pursuant to part 15 of the FCC Rules. These limits are designed to provide reasonable protection against harmful interference in a residential installation. This equipment generates, uses, and can radiate radio frequency energy, and, if not installed and used in accordance with the instructions, may cause harmful interference to radio communications. However, there is no guarantee that interference will not occur in a particular installation. If this equipment does cause harmful interference to radio or television reception, which can be determined by turning the equipment off and on, the user is encouraged to try to correct the interference by one or more of the following measures:
  - Reorient or relocate the receiving antenna.
  - Increase the separation between the equipment and receiver.
  - Connect the equipment into an outlet on a circuit different from that to which the receiver is connected.
  - Consult your dealer or an experienced radio/TV technician for help.
3. You are cautioned that changes or modifications not expressly approved by the party responsible for compliance could void your authority to operate the equipment.

## Important Information (continued)

---



### WARNING



TO PREVENT FIRE OR SHOCK HAZARDS, DO NOT EXPOSE THIS UNIT TO RAIN OR MOISTURE. ALSO, DO NOT USE THIS UNIT'S POLARIZED PLUG WITH AN EXTENSION CORD RECEPTACLE OR OTHER OUTLETS UNLESS THE PRONGS CAN BE FULLY INSERTED.

REFRAIN FROM OPENING THE CABINET AS THERE ARE HIGH VOLTAGE COMPONENTS INSIDE.  
REFER SERVICING TO QUALIFIED SERVICE PERSONNEL.



### CAUTION



CAUTION: TO REDUCE THE RISK OF ELECTRIC SHOCK, MAKE SURE POWER CORD IS UNPLUGGED FROM WALL SOCKET. TO FULLY DISENGAGE THE POWER TO THE UNIT, PLEASE DISCONNECT THE POWER CORD FROM THE AC OUTLET. DO NOT REMOVE COVER (OR BACK). NO USER SERVICEABLE PARTS INSIDE. REFER SERVICING TO QUALIFIED SERVICE PERSONNEL.



This symbol warns user that uninsulated voltage within the unit may have sufficient magnitude to cause electric shock. Therefore, it is dangerous to make any kind of contact with any part inside this unit.



This symbol alerts the user that important literature concerning the operation and maintenance of this unit has been included. Therefore, it should be read carefully in order to avoid any problems.

### CAUTION



This LCD Monitor uses a lamp that contains mercury. Disposal of the lamp or the LCD Monitor with the lamp may be regulated due to environmental considerations. For disposal or recycling information, please contact your local authorities or the Electronic Industries Alliance: [www.eiae.org](http://www.eiae.org). (For US only).



# Declaration

Declaration of the Manufacturer	
<p>We hereby certify that the color monitor MDT651S (BV928) is in compliance with</p> <p>Council Directive 2006/95/EC:</p> <ul style="list-style-type: none"><li>– EN 60950-1</li></ul> <p>Council Directive 2004/108/EC:</p> <ul style="list-style-type: none"><li>– EN 55022</li><li>– EN 61000-3-2</li><li>– EN 61000-3-3</li><li>– EN 55024</li></ul>	<p>and marked with</p>  <p>Mitsubishi Electric Corporation 2-7-3, Marunouchi, Chiyoda-Ku Tokyo 100-8310, Japan</p>

### Warning

This is a Class A product. In a domestic environment this product may cause radio interference, in which case the user may be required to take adequate measures.

Declaration of the Manufacturer	
	<p>Note: This symbol mark is for EU countries only.</p> <p>This symbol mark is according to the directive 2002/96/EC Article 10 Information for users and Annex IV, and/or to the directive 2006/66/EC Article 20 Information for end-users and Annex II.</p> <p>Your MITSUBISHI ELECTRIC product is designed and manufactured with high quality materials and components which can be recycled and/or reused.</p> <p>This symbol means that electrical and electronic equipment, batteries and accumulators, at their end-of-life, should be disposed of separately from your household waste.</p> <p>If a chemical symbol is printed beneath the symbol shown above, this chemical symbol means that the battery or accumulator contains a heavy metal at a certain concentration. This will be indicated as follows: Hg: mercury (0,0005%), Cd: cadmium (0,002%), Pb: lead (0,004%)</p> <p>In the European Union there are separate collection systems for used electrical and electronic products, batteries and accumulators.</p> <p>Please, dispose of this equipment, batteries and accumulators correctly at your local community waste collection/recycling centre.</p> <p>Please, help us to conserve the environment we live in!</p>

# Safety Precautions, Maintenance & Recommended Use

FOR OPTIMUM PERFORMANCE, PLEASE NOTE THE FOLLOWING WHEN SETTING UP AND USING THE LCD COLOR MONITOR:

- **DO NOT REMOVE MONITOR BACK COVER.** There are no user serviceable parts inside and opening or removing covers may expose you to dangerous shock hazards or other risks.  
Refer all servicing to qualified service personnel.
- Do not spill any liquids into the cabinet or use your monitor near water.
- Do not insert objects of any kind into the cabinet slots, as they may touch dangerous voltage points, which can be harmful or fatal or may cause electric shock, fire or equipment failure.
- Do not place any heavy objects on the power cord. Damage to the cord may cause shock or fire.
- Do not place this product on a sloping or unstable cart, stand or table, as the monitor may fall, causing serious damage to the monitor.
- When operating the LCD monitor with its AC 100-120 V power supply in North America, use a power supply cord provided with the monitor.  
If a power cord is not supplied with this monitor, please contact your supplier.
- When operating the LCD monitor with its AC 220-240 V power supply in Europe, use a power supply cord provided with the monitor.  
If a power cord is not supplied with this monitor, please contact your supplier.
- In UK, use a BS-approved power cord with molded plug having a black (10 A) fuse installed for use with this monitor.
- When operating the LCD Monitor with a 220-240 V AC power supply in Australia, use the power cord provided with the monitor.  
If a power cord is not supplied with this equipment, please contact your supplier.
- For all other cases, use a power cord that matches the AC voltage of the power outlet and has been approved by and complies with the safety standard of your particular country.
- Do not place any objects onto the monitor and do not use the monitor outdoors.
- The inside of the fluorescent tube located within the LCD monitor contains mercury. Please follow the bylaws or rules of your municipality to dispose of the tube properly.
- Do not bend power cord.
- Do not use monitor in high temperature, humid, dusty, or oily areas.
- If monitor or glass is broken, do not come in contact with the liquid crystal and handle with care.
- If the LCD monitor is damaged and the liquid crystal leaks out, do not inhale or swallow it.
- Allow adequate ventilation around the monitor, so that heat can properly dissipate. Do not block ventilated openings or place the monitor near a radiator or other heat sources.  
Do not put anything on top of the monitor.
- The power cable connector is the primary means of detaching the system from the power supply. The monitor should be installed close to a power outlet, which is easily accessible.

- Handle with care when transporting. Save packaging for transporting.
- Please clean the holes of back cabinet to reject dirt and dust at least once a year because of set reliability.
- If using the cooling fan continuously, it's recommended to wipe holes a minimum of once a month.
- When installing the remote control batteries;
  - Align the batteries according to the (+) and (-) indications inside the case.
  - Align the (-) indication of the batteries first inside the case.



## CAUTION:

Immediately unplug your monitor from the wall outlet and refer servicing to qualified service personnel under the following conditions:

- When the power supply cord or plug is damaged.
- If liquid has been spilled, or objects have fallen into the monitor.
- If the monitor has been exposed to rain or water.
- If the monitor has been dropped or the cabinet damaged.
- If the monitor does not operate normally by following operating instructions.

## Recommend Use

### CAUTION:

- For optimum performance, allow 20 minutes for warm-up.
- Rest your eyes periodically by focusing on an object at least 5 feet away. Blink often.
- Position the monitor at a 90° angle to windows and other light sources to minimize glare and reflections.
- Clean the LCD monitor surface with a lint-free, non-abrasive cloth. Avoid using any cleaning solution or glass cleaner!
- Adjust the monitor's brightness, contrast, and sharpness controls to enhance readability.
- Avoid displaying fixed patterns on the monitor for long periods of time to avoid image persistence (after image effects).
- Get regular eye checkups.

### Ergonomics

To realize the maximum ergonomic benefits, we recommend the following:

- Use the preset Size and Position controls with standard signals.
- Use the preset Color Setting.
- Use non-interlaced signals.
- Do not use primary color blue on a dark background, as it is difficult to see and may produce eye fatigue due to insufficient contrast.

# Contents

Your LCD monitor (MDT651S) comes with the following:

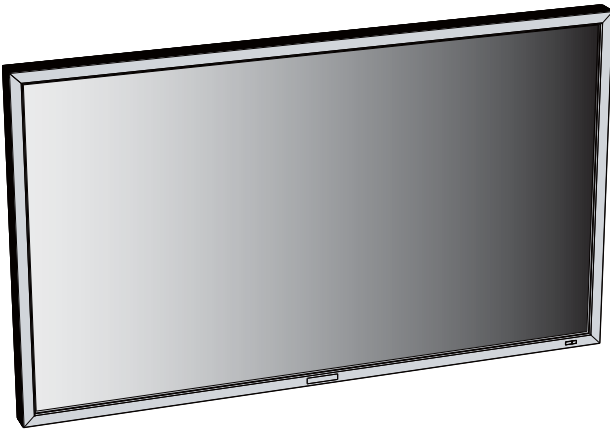

□ LCD Monitor



☑ User's Manual

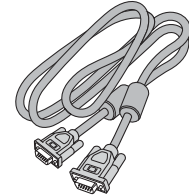

□ Video Signal Cable  
(Mini D-SUB 15-pin to Mini D-SUB 15-pin Cable)



□ CAT5 Tx BOX

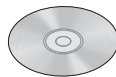

□ CD-ROM

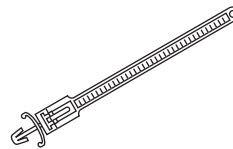

□ Clasper x 2  
(For preventing disconnection of the power cord and HDMI cable)



□ Clasper x 2  
(For securing the cables)



□ Wireless Remote Control and AAA Batteries

\* The supplied power cord varies depending on destination.

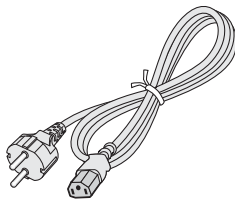

□ Power Cord  
For EU

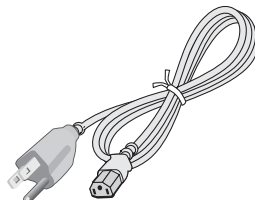

□ Power Cord  
For North America



□ Protective cover



□ Label to cover the UL certification marking

\* For the use in the other regions, use a power cord that matches the AC voltage of the power outlet and has been approved by and complies with the safety standard of those regions or countries.

The following components are supplied as option.

- External Speakers

# Parts Name and Functions

## Buttons, Switch, and Indicator

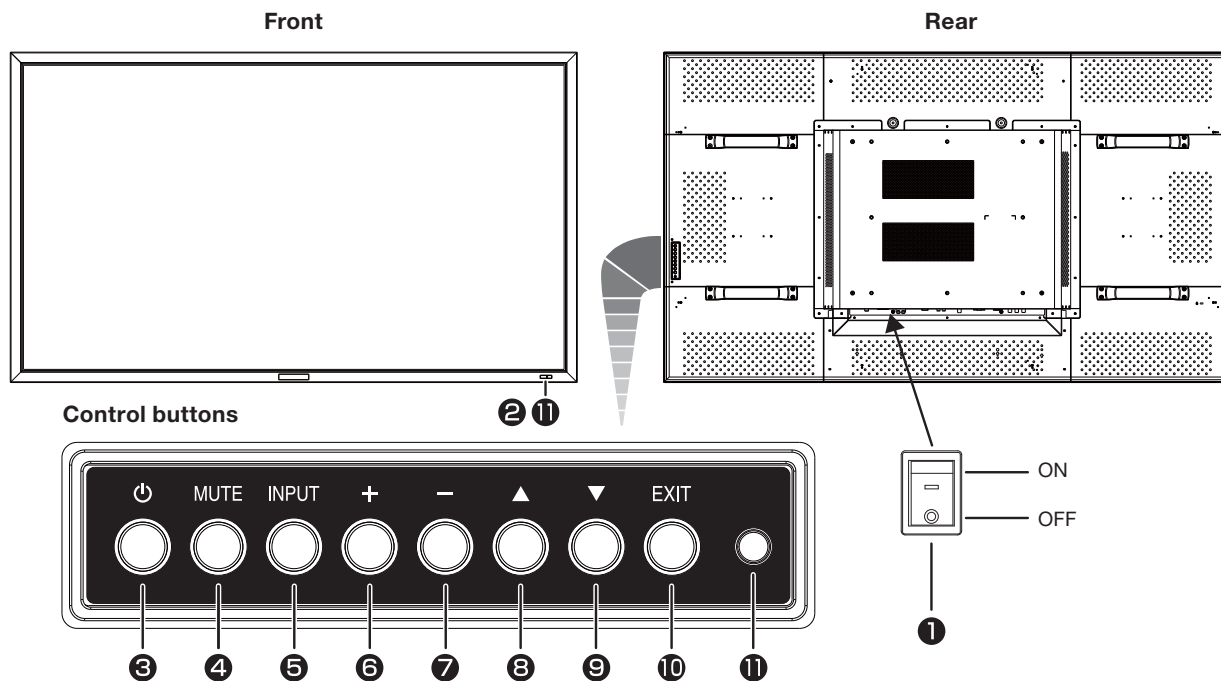

### ❶ Main Power Switch

Switches the main power on/off.

### ❷ Remote control sensor and Power indicator

Remote control sensor: Receives the signal from the wireless remote control.

Power indicator: Indicates the state of the LCD monitor.

- Steady green: The power is on.
- Steady red: The power is off.  
Some operations such as power-on are possible.
- Steady green and red: The LCD monitor is in the sleep mode.
- Off: The main power is off.
- Steady red and blinking green: The LCD monitor is in the schedule standby mode.
- Blinking red: The LCD monitor has an error (detected by the self-diagnostic function).

### ❸ POWER button (⏻)

Switches the power on/off.

This button doesn't work when the power indicator is off.

Turn on the main power. (See page 29.)

### ❹ MUTE button

Switches the audio mute on/off.

### ❺ INPUT button

Displays the OSD menu to switch the video input.

You can select [RGB1], [RGB2], [RGB3], [RGB4], [RGB5], [RGB6], [DVD/HD], [VIDEO<S>], or [VIDEO] using the UP (▲) or DOWN (▼) button.

### ❻ PLUS (+) button

Acts as (+) button to increase the adjustment in the OSD menu. Increases the audio output level when the OSD menu is off.

### ❼ MINUS (-) button

Acts as (-) button to decrease the adjustment in the OSD menu. Decreases the audio output level when the OSD menu is off.

### ❽ UP (▲) button

Activates the OSD menu when the OSD menu is off.

Acts as ▲ button to move the highlighted area up to select an adjustment item in the OSD menu.

### ❾ DOWN (▼) button

Activates the OSD menu when the OSD menu is off.

Acts as ▼ button to move the highlighted area down to select an adjustment item in the OSD menu.

### ❿ EXIT button

Activates the OSD menu when the OSD menu is off.

Acts as EXIT button to go back to the previous OSD menu.

### ⓫ Brightness sensor (on the front and rear)

Sensor for the auto brightness function.

### (Reference) Control Lock mode

You can lock the operation buttons. See page 51.

#### NOTE:

For details about the OSD menu operation using the buttons, see "Basic operation of OSD." (See page 40.)

# Parts Name and Functions (continued)

## Connectors and Terminals

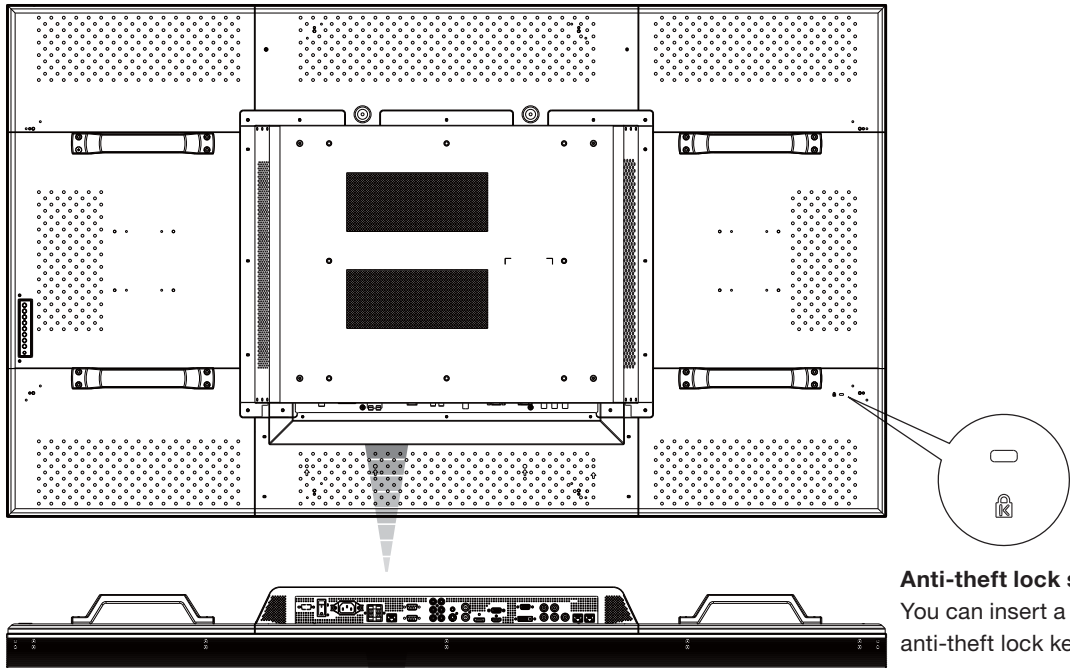

**Anti-theft lock slot**  
You can insert a Kensington anti-theft lock key.

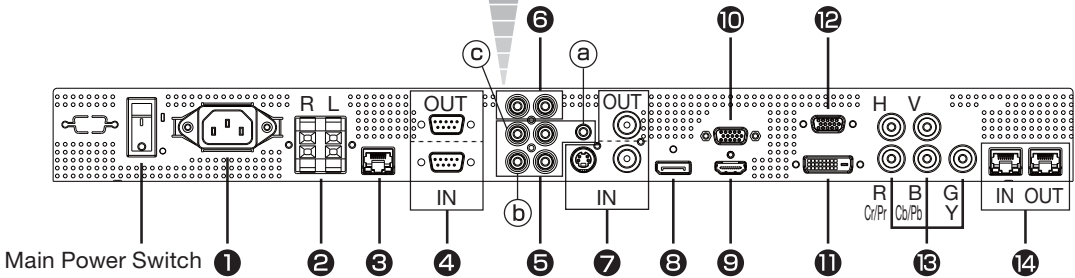

- 1 AC IN (3-pin, with earth terminal)**  
Connects with the supplied power cord.
- 2 EXTERNAL SPEAKER TERMINAL**  
Connects with the special stereo speakers (option).
- 3 LAN connector**  
Connects with a LAN cord.
- 4 RS-232C connector (D-SUB 9-pin)**  
IN connector:  
Connects with the RS-232C OUT connector of a computer or other connected MDT651S.  
OUT connector:  
Connects with the RS-232C IN connector of other connected MDT651S.
- 5 AUDIO IN**  
Connects with the audio output connector of external equipment such as a computer, VCR, and DVD player.  
(a) AUDIO1: ø3.5 stereo mini-jack connector  
(b) AUDIO2: RCA connector  
(c) AUDIO3: RCA connector
- 6 AUDIO OUT (RCA)**  
Outputs the signal that is supplied to the selected AUDIO IN connector. Connects with an external audio amplifier, etc.
- 7 VIDEO INPUT/OUTPUT (BNC/S connector)**  
Connects with video equipment.  
S VIDEO IN: S-video input connector (MINI DIN 4-pin)  
VIDEO IN: BNC connector  
VIDEO OUT: BNC connector

- 8 RGB6 IN (DisplayPort)**  
Connects with the digital video output of a computer, etc.
- 9 RGB1 IN (HDMI)**  
Connects with the digital video output of a computer, DVD player, etc.
- 10 RGB OUT (MINI D-SUB 15-pin)**  
Outputs the signal that is supplied to the RGB3 or RGB4 IN connector.
- 11 RGB2 IN (DVI-D)**  
Connects with the digital video output of a computer, etc.
- 12 RGB3 IN (MINI D-SUB 15-pin)**  
Connects with the analog video output of a computer, etc.
- 13 RGB4 IN, DVD/HD IN (BNC)**  
Connects with the analog video output of a computer or the component video output of a DVD player, etc.
- 14 RGB5, CAT5 INPUT/OUTPUT (Modular connector 8-pin)**  
IN connector:  
Connects with the CAT5 OUT connector of a CAT5 Tx BOX or other connected MDT651S.  
OUT connector:  
Connects with the CAT5 IN connector of other connected MDT651S.

# Parts Name and Functions (continued)

## Wireless Remote Control

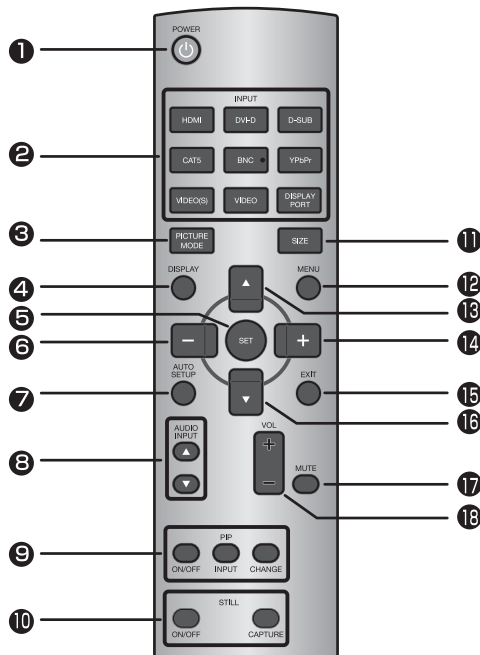

### 1 POWER button

Switches the power on/off.

\* When the Power indicator is not glowing, no controls will work.

### 2 INPUT buttons

Select the input signal from [RGB1] (HDMI), [RGB2] (DVI-D), [RGB3] (D-SUB), [RGB4] (BNC), [RGB5] (CAT5), [RGB6] (DISPLAY PORT), [DVD/HD] (YPbPr), [VIDEO<S>], and [VIDEO].

### 3 PICTURE MODE button

Selects the picture mode from [HIGHBRIGHT], [STANDARD], [sRGB], and [CINEMA]. See page 32.

HIGHBRIGHT: The brightness is maximized.

STANDARD: Factory default setting.

sRGB: Suitable for color matching with sRGB-compliant devices.

CINEMA: Suitable for viewing movies.

### 4 DISPLAY button

Displays the screen information. See page 51. When the remote control mode is LOCK, you can set it back to NORMAL by holding down the DISPLAY button for at least 5 seconds (see page 49).

### 5 SET button

Accepts the settings made in the OSD menu.

### 6 MINUS button (-)

Acts as (-) button to decrease the adjustment in the OSD menu. When the PIP mode is active, this button moves the sub picture to the left.

### 7 AUTO SETUP button

Displays the auto setup menu. See pages 32 and 46.

### 8 AUDIO INPUT buttons

Select the audio input from [AUDIO1], [AUDIO2], [AUDIO3], and [HDMI]. However, note that [VIDEO<S>] and [VIDEO] use common settings. You can select [HDMI] only when the video input source is [RGB1].

### 9 PIP (Picture-in-Picture) buttons

ON/OFF button: Switches the PIP or POP mode on/off.

INPUT button: Selects video to be displayed in the sub picture.

CHANGE button: Changes the main picture with the sub picture.

#### [Description]

PIP: Picture-in-Picture

The sub picture is displayed within the main picture.

POP: Picture-out-Picture

The sub picture is displayed to the bottom right of the main picture.

SIDE BY SIDE

The main picture and the sub picture are displayed side by side.

#### NOTE:

When the screen size is [CUSTOM] or [REAL], the PIP and POP modes don't work.

### 10 STILL button

ON/OFF button: Switches the still picture mode on/off.

CAPTURE button: Captures the new picture.

### 11 SIZE button

Selects the picture size from [FULL], [NORMAL], [CUSTOM], [DYNAMIC], and [REAL]. See page 51.

### 12 MENU button

Switches the OSD menu mode on/off.

### 13 UP button (▲)

Acts as ▲ button to move the highlighted area up to select an adjustment item in the OSD menu. When the PIP mode is active, this button moves the sub picture up.

### 14 PLUS button (+)

Acts as (+) button to increase the adjustment in the OSD menu. When the PIP mode is active, this button moves the sub picture to the right.

### 15 EXIT button

Displays the previous OSD menu.

### 16 DOWN button (▼)

Acts as ▼ button to move the highlighted area down to select an adjustment item in the OSD menu. When the PIP mode is active, this button moves the sub picture down.

### 17 MUTE button

Switches the mute function on/off.

### 18 VOLUME buttons (VOL)

Pressing the plus (+) side increases the audio output level.

Pressing the minus (-) side decreases the audio output level.

## Parts Name and Functions (continued)

### How to Use the Wireless Remote Control

#### Operating Range of the Wireless Remote Control

Point the wireless remote control toward the LCD monitor's remote control sensor during button operation.

Use the wireless remote control within a distance of about 7 m from the front of the LCD monitor's remote control sensor and at a horizontal and vertical angle of within 30° within a distance of about 3.5 m.

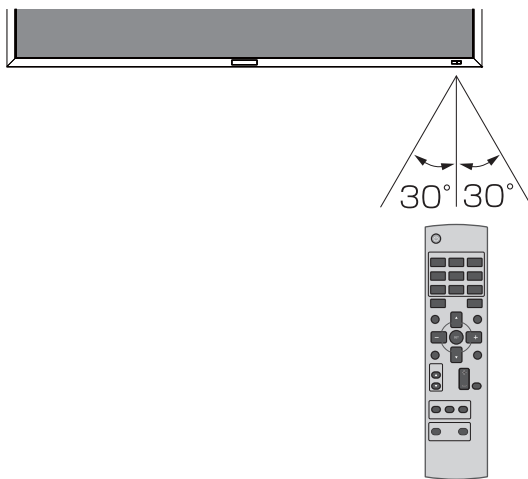

#### CAUTION:

The remote control system may not function when direct sunlight or strong illumination strikes the remote control sensor of the LCD monitor, or when there is an object in the path.

#### Handling the wireless remote control

- \* Do not subject to strong shock.
- \* Do not allow water or other liquid to splash on the wireless remote control. If the wireless remote control gets wet, wipe it dry immediately.
- \* Avoid exposure to heat and steam.
- \* Other than to install the batteries, do not open the wireless remote control.

#### Installing and removing the Wireless remote control batteries

The wireless remote control is powered by 1.5 V AAA batteries.

##### How to install the batteries

1. Unlock and pull up the cover in the arrow's direction.
2. Align the batteries according to the (+) and (-) indications inside the case.
3. Replace the cover.

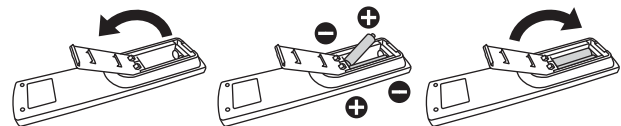

##### How to remove the batteries

1. Unlock and pull up the cover in the arrow's direction.
2. Remove the batteries.

#### CAUTION:

Incorrect use of batteries can result in leaks or explosion.

Be careful especially about the following points.

- Place "AAA" batteries matching the (+) and (-) signs on each battery to the (+) and (-) signs of battery compartment.
- Do not mix battery types.
- Do not combine new batteries with used ones. It causes shorter battery life or leakage of batteries.
- Remove dead batteries immediately to prevent battery liquid from leaking into the battery compartment. Don't touch exposed battery acid because it causes damage to your skin.

#### NOTE:

If you do not use the wireless remote control for a long period, remove the batteries.

## Parts Name and Functions (continued)

### CAT5 Tx BOX

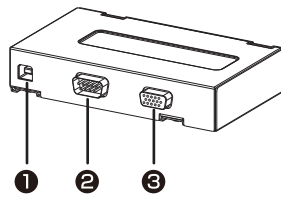

Front

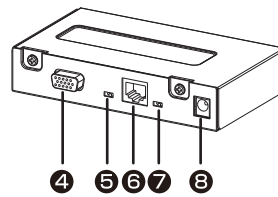

Rear

#### ① USB (B type)

Connector for receiving the power supplied from the USB device such as the computer. By connecting a USB cable, you can control the CAT5 Tx BOX using the control commands transmitted over the USB cable.

#### CAUTION:

We have checked that the power is supplied and the control commands are transmitted properly via the USB connector by connecting it with our computers according to the USB standards.

When the CAT5 Tx BOX is combined with your computer system or USB hub system, check in advance that it operates properly.

#### ② EXTERNAL CONTROL (D-SUB 9-pin)

When the communication via the USB connector is unusable, this connector can be used for RS-232C communication with the control device such as the computer.

#### NOTE:

RS-232C connection isn't necessary when the COM port number set by the USB driver is used. Make selection using the input select switch (USB/RS-232C) (⑤), as necessary.

#### ③ RGB IN (MINI D-SUB 15-pin)

Connector for receiving the analog RGB video signal from the computer.

#### ④ RGB OUT (MINI D-SUB 15-pin)

Video connector for buffering and outputting the analog RGB video signal received by the RGB IN connector (③).

#### ⑤ Input select switch (USB/RS-232C)

Switches the control input between the USB connector and the RS-232C connector.

#### ⑥ CAT5 OUT (Modular connector 8-pin)

Connector for converting and outputting the video signal received by the RGB IN connector (③) and the control signal transmitted via the USB connector (①) or the RS-232C connector (②) to transmit them on the CAT5 long cable.

#### CAUTION:

Never connect network devices to the CAT5 IN and OUT connectors. If you do so, they may adversely affect with each other, causing breakdown.

#### ⑦ Composite sync signal level switch

Switches the composite sync signal level.

The TTL level and the 0.3 V level are switched.

#### ⑧ Auxiliary power supply input connector (DC IN 5 V)

Though the power is supplied from the above-mentioned USB connector, an auxiliary DC power adapter (commercially available) is also available. When +5 V (according to the product specifications) is supplied from the above-mentioned DC power adapter, the power supply is automatically switched from the USB connector. (You cannot use both at the same time.)

#### CAUTION:

- Don't apply a voltage out of the specified range to the auxiliary power supply input connector or connect it with incorrect polarity. If you do so, the connected devices may be overheated or damaged.
- The auxiliary power supply input connector isn't intended for general use. Commercial DC power connectors are available in different shapes. When you want to use this connector, consult a qualified electrician or your dealer in advance.

Power connector type: DC jack R/A type (Diameter of the center pin: 2.0 mm)

Pin	Name	Definition
1	+5 V	DC Power source
2	GND	GND

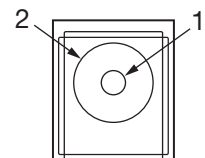



# Preparation for use

## Flow of preparation

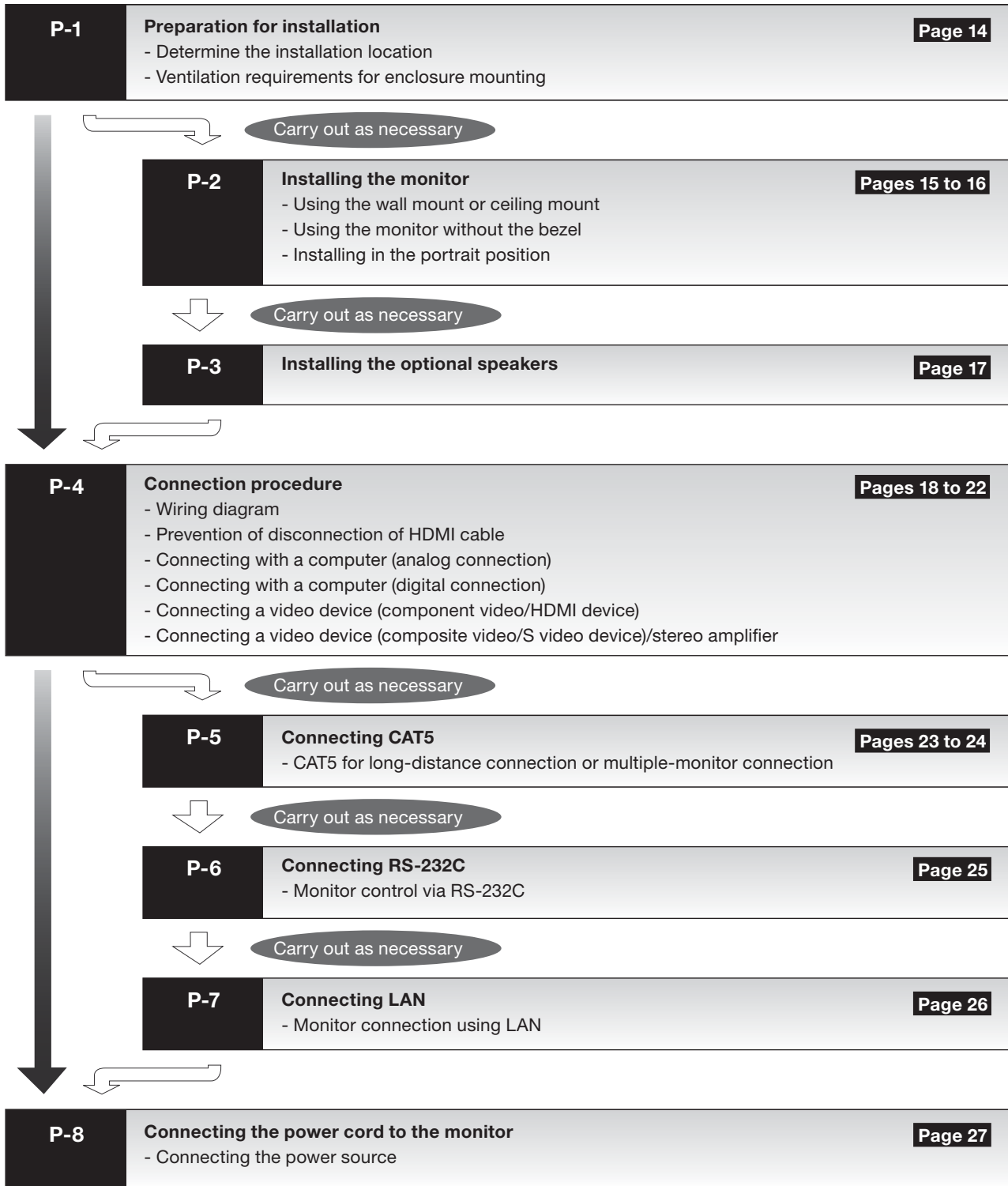

The monitor is ready for use.

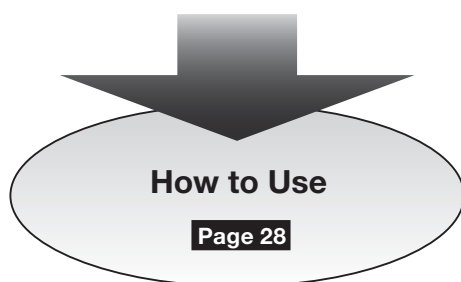

# P-1

## Preparation for installation

Install the monitor on a wall or ceiling strong enough to support its weight where the screen is easy to view, using commercially available wall or ceiling mount brackets.

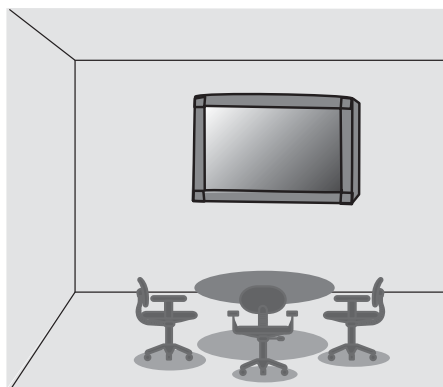

### Determine the installation location

**CAUTION:**

DO NOT ATTEMPT TO INSTALL THE LCD MONITOR BY YOURSELF.

Installing your LCD monitor must be done by a qualified technician. Contact your dealer for more information.

**CAUTION:**

MOVING OR INSTALLING THE LCD MONITOR MUST BE DONE BY THREE OR MORE PEOPLE.

Failure to follow this caution may result in injury if the LCD monitor falls.

**CAUTION:**

Do not mount or operate the monitor upside down, face up, or face down.

**IMPORTANT:**

Lay the protective sheet, which was wrapped around the LCD monitor when it was packaged, beneath the LCD monitor so as not to scratch the panel.

### Ventilation requirements for enclosure mounting

To allow heat to disperse, leave space around the monitor as shown in the figure below.

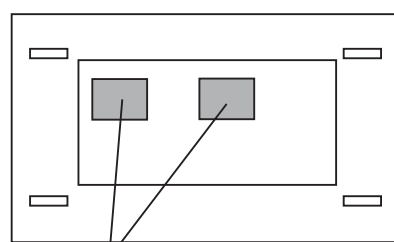
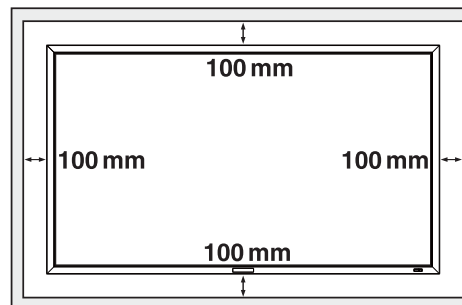

Don't block these holes.

**CAUTION:**

Don't block the holes in the rear of the monitor shown in the figure above. If they are blocked, heat accumulates inside the monitor, causing breakdown. The upper limit of the operation-guaranteed ambient temperature when the monitor is installed in the landscape position is 40°C. When installing the monitor in a case or an enclosure, ensure adequate ventilation to keep the temperature inside the case 40°C or lower by providing a cooling fan or ventilation holes in the case. The upper limit when the monitor is in the portrait position is 35°C.

This LCD has a temperature sensor and cooling fan. If the LCD becomes hot, the cooling fan will turn on automatically. If the LCD becomes overheated, the "Caution" menu will appear. If the "Caution" menu appears, stop using the monitor and allow it to cool. When the LCD monitor is used in an enclosure or with protection on LCD surface, please check the inside temperature of the monitor by "HEAT STATUS" (See page 50). If the temperature is higher than the normal level, set "COOLING FAN" to ON using the SCREEN SAVER function (See page 46).

## Using the wall mount or ceiling mount

### Lay the screen face down

Lay the protective sheet on a table, which was wrapped around the monitor when it was packaged, beneath the screen surface so as not to scratch the screen surface.

Failure to follow the correct mounting procedures can result in damage to the equipment or injury to the user or installer. Product warranty does not cover damage caused by improper installation.

Failure to follow these recommendations can void your warranty.

Use M8 screws (having a length 15 mm longer than the thickness of the mounting bracket) and tighten them securely. Prevent the screws from loosening using spring washers, etc. MITSUBISHI ELECTRIC recommends using mounting interface that comply with TÜV-GS and/or UL1678 standard in North America.

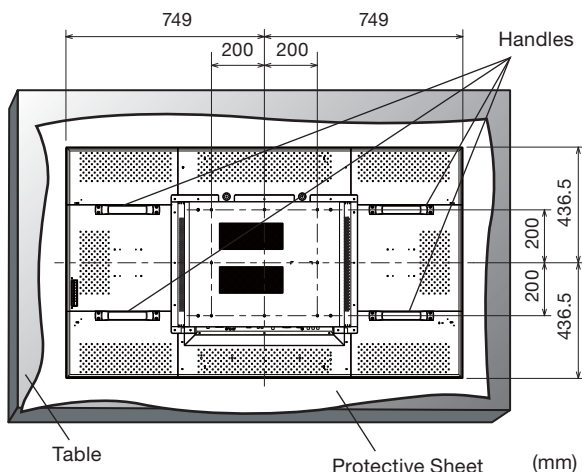

### CAUTION:

For preventing the monitor from falling.

- Install the monitor with metal brackets for wall or ceiling installation (commercially available) on your own responsibility. For detailed procedures of installation, refer to the instructions of the metal brackets.
- To lessen the probability of injury and damage resulting from fall of the monitor in case of earthquake or other disaster, be sure to consult the bracket manufacturer for installation location.
- To lessen the risk of falling of the monitor, thread commercially available rope through the handles at the right and left of the monitor and secure the rope to the wall mount brackets or ceiling mount brackets.
- Do not sleep where the monitor may topple over or fall in case of an earthquake or other disaster.
- Use screws having enough strength to support the LCD display monitor (made of stainless steel etc.).

## Using the monitor without the bezel

### CAUTION:

- MDT651S satisfies the UL requirements as long as it is used with the bezel attached. When using the monitor without the bezel, in which case the monitor doesn't satisfy the UL requirements, cover the UL certification marking on the rear panel with the supplied label.
  - To prevent static damage to circuit boards, attach the protective cover to the LCD panel.
1. Unscrew the screws that hold the bezel to remove the bezel from the monitor.

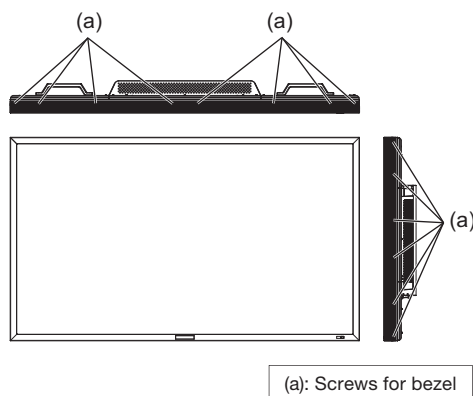

2. Place the supplied protective cover (b) on the LCD panel using double-sided adhesive tape.

### CAUTION:

Never touch the circuit boards because they may be damaged.

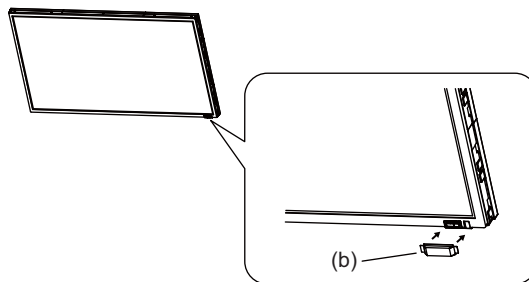

3. Cover the UL certification marking on the rear panel with the supplied label (c).

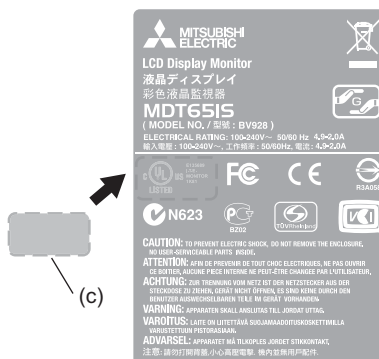

**Installing in the portrait position****Conditions:**

MDT651S can be installed in the portrait position, under the following conditions:

**CAUTION:**

Portrait position is available only when the monitor is wall-mounted or ceiling-mounted.

Operation Environment (Temperature) shall be limited, as shown below:

**Operation Environment:**

Temperature	5 - 35°C / 41 - 95°F
Humidity	20 - 80% (without condensation)

Place the monitor in the position shown below.

Do not place the monitor in landscape in any other manner than shown.

Optional speakers (SP-521S) can not be attached when the LCD monitor is installed in the portrait position.

**How to set-up**

The “ MITSUBISHI” logo should be on the LEFT side when viewed from the front of the monitor.

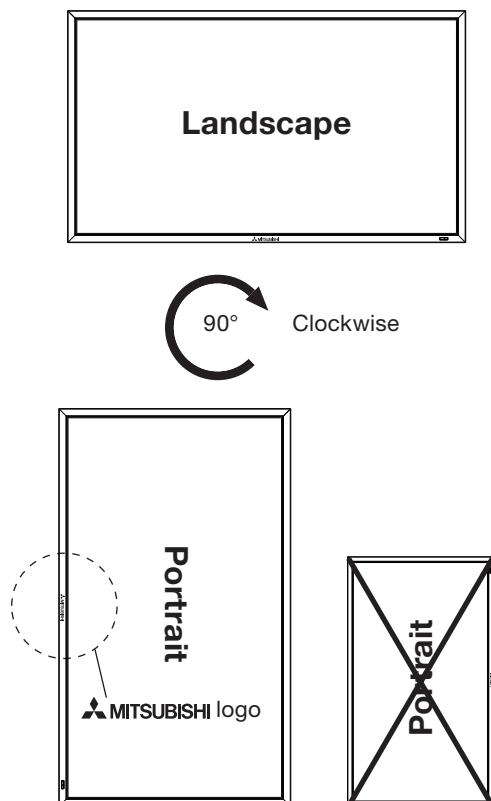

**Before connecting the signal cable to PC and Video**

- Optional speakers can be installed.
- Please refer to Quick Setup Guide of the optional speakers for the detailed installation procedure.

**How to install the optional speakers**

1. Use the metal fittings and screws supplied with the optional speakers.  
For the installation procedure, see the setup guide of the speakers.
2. Insert the left speaker cable into the SPEAKER (S) terminal (L) on the monitor, and insert the right speaker cable into the SPEAKER (S) terminal (R).

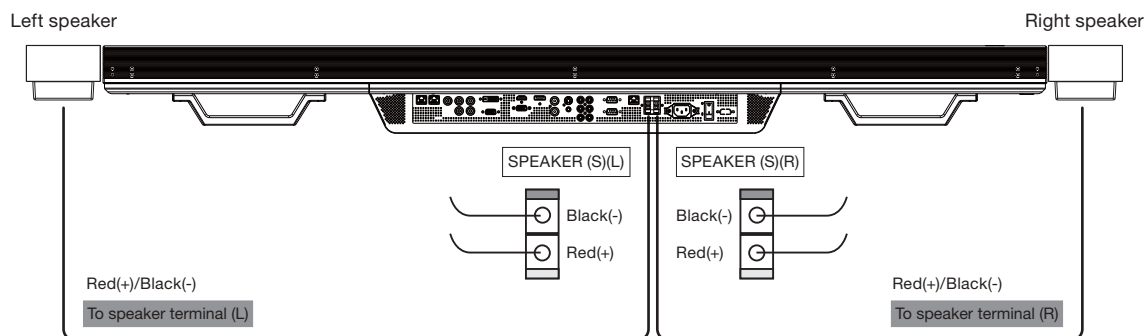
**NOTE:**

Match the polarity of the speaker cables and that of the terminals (+ (red)/- (black)).  
Unmatched polarity may cause problems with audio output.

**CAUTION:**

Do not move the monitor with the speakers installed.  
The monitor and the speakers may be damaged and you may be injured if the monitor falls.

# P-4 Connection procedure

## Before making connections

- First turn off the power of all the connected equipment before making connections.
- Refer to the user manual of each piece of equipment.

## NOTE:

Please use the audio cable without resistance when the audio output terminal of the audio device and PC is stereo mini-Jack. When the audio cable with resistance is used, the audio level may not be increased or no audio may be output.

## Wiring diagram

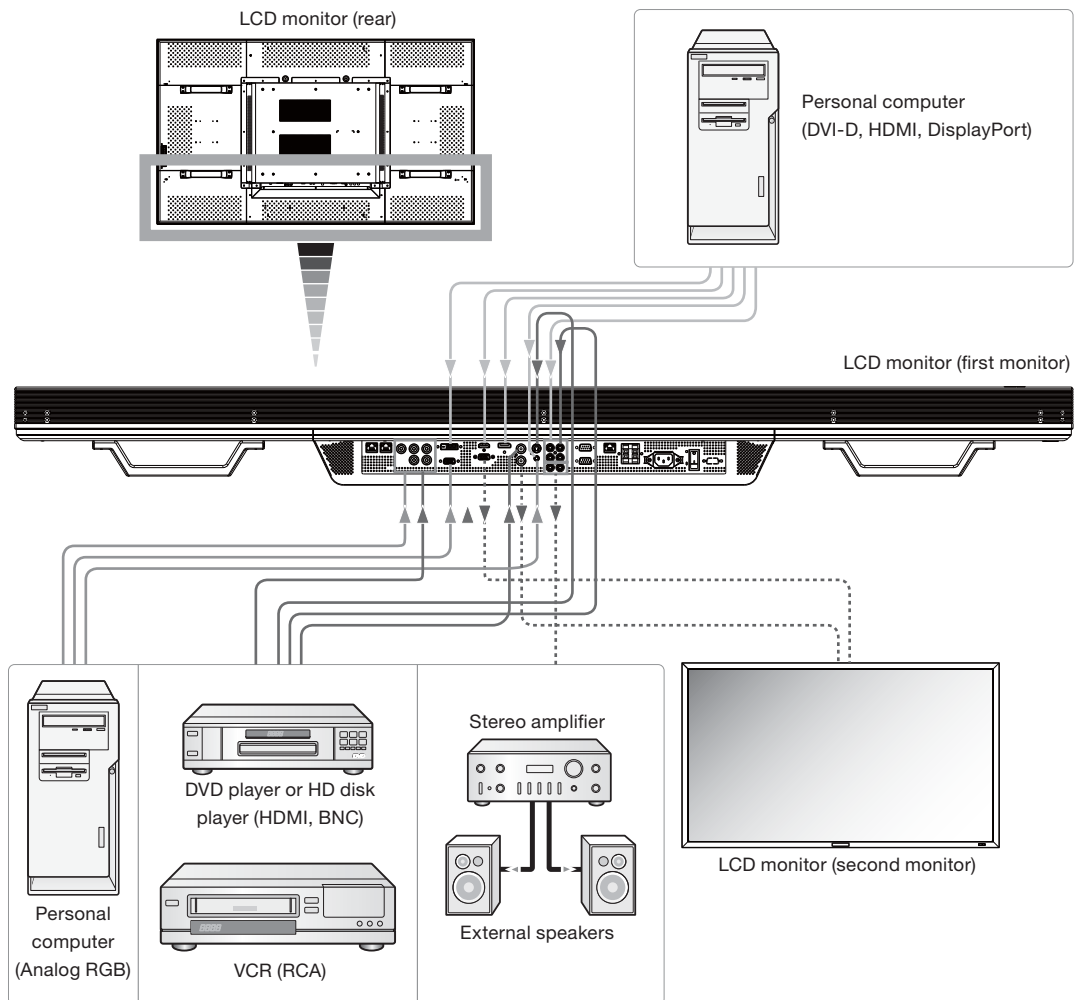

## Prevention of disconnection of HDMI cable

When you connect the HDMI cable to the connector on the monitor, in order to prevent accidental disconnection of the cable, you are recommended to secure it using the supplied clammer as shown in the figure.

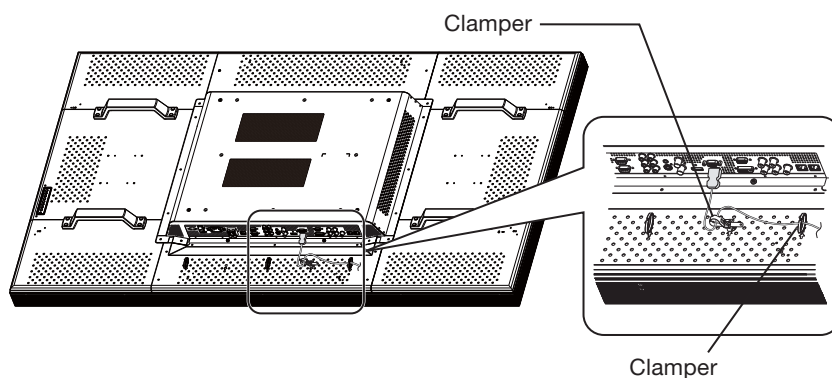

## P-4 Connection procedure (continued)

### Connecting with a computer (analog connection)

#### Analog connection:

##### • Connection via RGB3 IN (D-SUB) connector

- (1) Connect a signal cable (mini D-SUB 15-pin – mini D-SUB 15-pin) (accessory) to the RGB3 IN connector.
- (2) Select [RGB3] using the INPUT button on the monitor or the D-SUB button on the wireless remote control.

##### • Connection via RGB4 IN (BNC: R•G•B•H•V, or R•G•B•Csync, RGB sync on green) connector

- (1) Use a BNC cable (BNC x 5 - BNC x 5) (commercially available) to connect the BNC connector on the PC, and use a signal cable (mini D-SUB 15-pin - BNC x 5) (commercially available) to connect the mini D-SUB 15-pin connector on the PC.
- (2) Select [RGB4] using the INPUT button on the monitor or the BNC button on the wireless remote control.

#### Second monitor connection:

- Connect the RGB OUT connector (mini D-SUB 15-pin) on the first monitor and the RGB3 IN connector (mini D-SUB 15-pin) on the second monitor using a signal cable (mini D-SUB 15-pin - mini D-SUB 15-pin) (an accessory of the second monitor or commercially available).  
(The RGB3 or RGB4 signal selected by the first monitor is output. The RGB1 or RGB2 signal isn't output.)

#### Audio connection:

- Connect an audio cable (ø3.5 mm stereo mini) (commercially available) to the AUDIO IN1 connector. Select [AUDIO1] using the AUDIO INPUT buttons on the wireless remote control.
- To output audio to the second monitor:  
Connect the AUDIO OUT connector on the first monitor and the AUDIO IN2 or 3 connector on the second monitor using an audio cable (RCA) (commercially available).

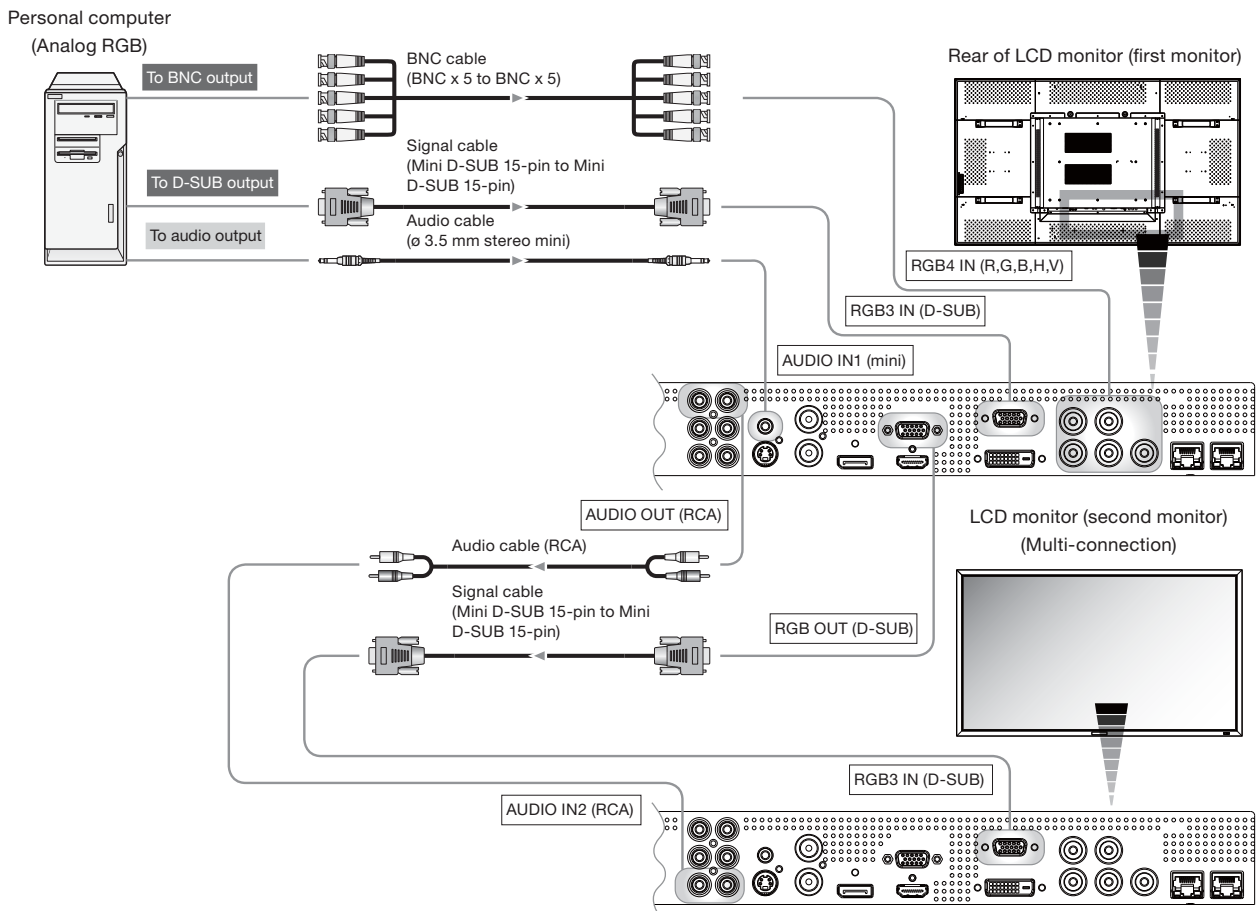

## P-4 Connection procedure (continued)

The monitor automatically distinguishes the timings shown in the table below and sets the screen information. When a PC or other device is connected, it automatically displays images properly. See the page describing AUTO SETUP/AUTO ADJUST.

### <Factory preset timing>

	Resolution	Frequency		Remarks		Resolution	Frequency		Remarks
		Horizontal	Vertical				Horizontal	Vertical	
1	640 x 480	31.5 kHz	60 Hz		6	1280 x 1024	64.0 kHz	60 Hz	
2	800 x 600	37.9 kHz	60 Hz		7	1600 x 1200	75.0 kHz	60 Hz	
3	1024 x 768	48.4 kHz	60 Hz		8	1920 x 1080	67.5 kHz	60 Hz	Recommend timing
4	1280 x 768	48.0 kHz	60 Hz		9	1920 x 1200	74.0 kHz	60 Hz	
5	1360 x 768	47.7 kHz	60 Hz						

### NOTE:

When a signal other than 1920x1080 is input, characters may be blurred and figures and objects may be distorted. Images may not be displayed correctly depending on the video card or driver being used.

## Connecting with a computer (digital connection)

### Digital connection:

- **Connection via the RGB1 IN connector (HDMI)**

- (1) Connect an HDMI cable (commercially available) to the RGB1 IN connector.
- (2) Select [RGB1] using the INPUT button on the monitor or the HDMI button on the wireless remote control.

- **Connection via the RGB2 IN connector (DVI-D)**

- (1) Connect a DVI-D cable (commercially available) to the RGB2 IN connector.
- (2) Select [RGB2] using the INPUT button on the monitor or the DVI-D button on the wireless remote control.

- **Connection via the RGB6 IN connector (DisplayPort)**

- (1) Connect a DisplayPort cable (commercially available) to the RGB6 IN connector.
- (2) Select [RGB6] using the INPUT button on the monitor or the DISPLAY PORT button on the wireless remote control.

### Audio connection:

- **Connect an audio cable (ø3.5 mm stereo mini) (commercially available) to the AUDIO IN1 connector.**

Select [AUDIO1] using the AUDIO INPUT buttons on the wireless remote control.

When an HDMI cable is connected, select HDMI audio.

(You can select HDMI only when the video input is [RGB1].)

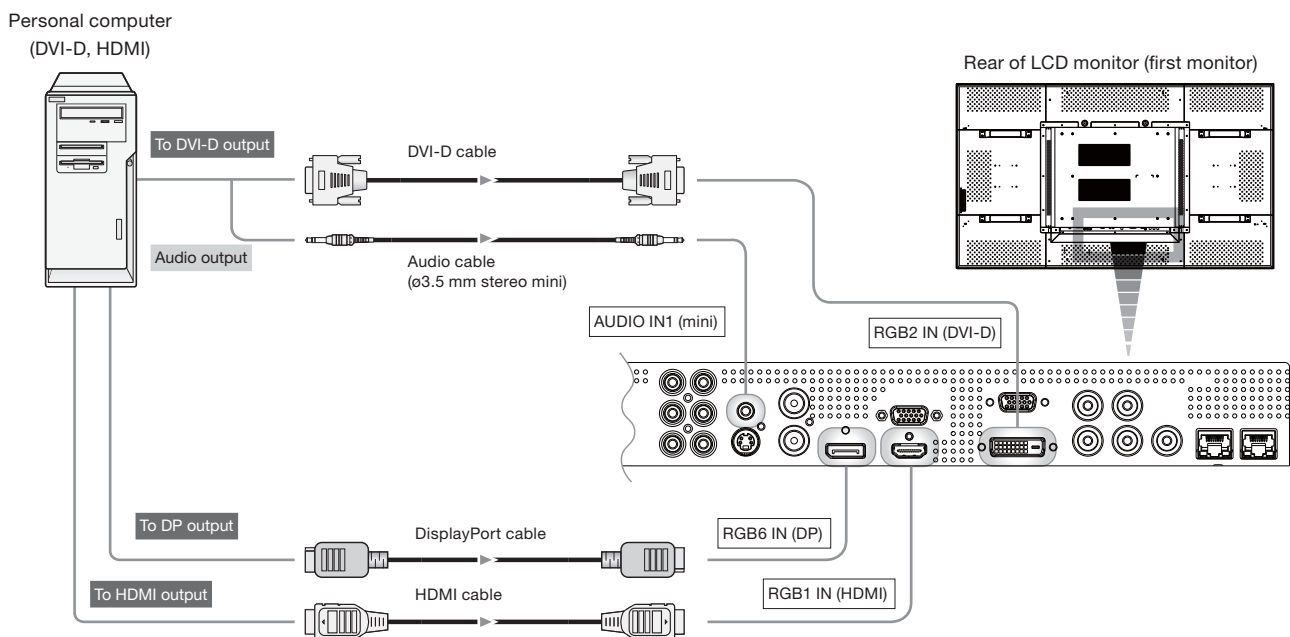



## P-4 Connection procedure (continued)

### Connecting a video device (component video/HDMI device)

This monitor can be connected to a video device equipped with component output such as a DVD player.

Refer to the user's manual of the connected device for details. (Cables shown in the figure below are commercially available.)

- To connect a DVD player equipped with component output to the DVD/HD IN connector (YPbPr or YCbCr) on the monitor, use a BNC cable (BNC x 3 – BNC x 3) and a BNC-RCA adaptor (commercially available), or a signal cable (BNC x 3 – D connector). Select [DVD/HD] using the INPUT button on the monitor or the YPbPr button on the wireless remote control.
- To make audio connection, connect an audio cable (RCA) to the AUDIO IN2 connector or the AUDIO IN3 connector. Select [AUDIO2] or [AUDIO3] using the AUDIO INPUT buttons on the wireless remote control.
- To connect a DVD player equipped with HDMI output to the RGB1 IN connector (HDMI) on the monitor, use an HDMI signal cable. Select [RGB1] using the INPUT button on the monitor or the HDMI button on the wireless remote control.
- For HDMI cable connection, select HDMI audio.  
(You can select HDMI audio only when the video input is [RGB1].)

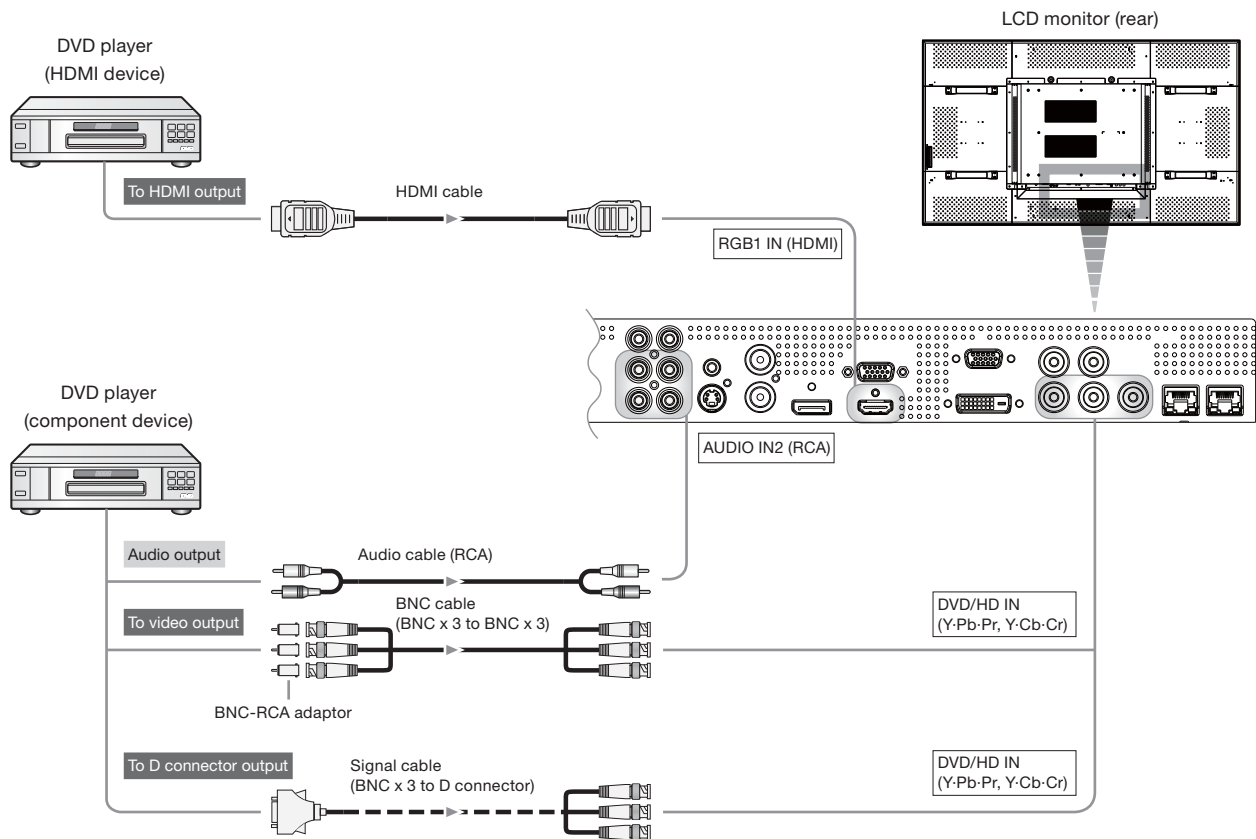

## P-4 Connection procedure (continued)

### Connecting a video device (composite video/S video device)/stereo amplifier

This monitor can be connected to a stereo amplifier.

Refer to the user's manual of the stereo amplifier for details. (Cables shown in the figure below are commercially available.)

- To connect a video device to the VIDEO IN connector (VIDEO IN or S-VIDEO IN) on the monitor, use a BNC cable or an S video cable. For connection to the audio input connector on the monitor, use an audio cable (RCA). Connect the connectors of the audio cable (RCA) correctly. For connection to the VIDEO IN connector, select [VIDEO] using the INPUT button on the monitor or the VIDEO button on the wireless remote control. For connection to the S-VIDEO IN connector, select [VIDEO<S>] using the INPUT button on the monitor or the VIDEO(S) button on the wireless remote control.
- When connecting a stereo amplifier to the monitor, be sure to turn off the power of the stereo amplifier. For connection to the audio output connector on the monitor, use an audio cable (RCA). Connect the connectors of the audio cable (RCA) correctly. Be sure to turn on the monitor first, and then turn on the stereo amplifier.
- The selected audio input signal is output from the AUDIO OUT connector.

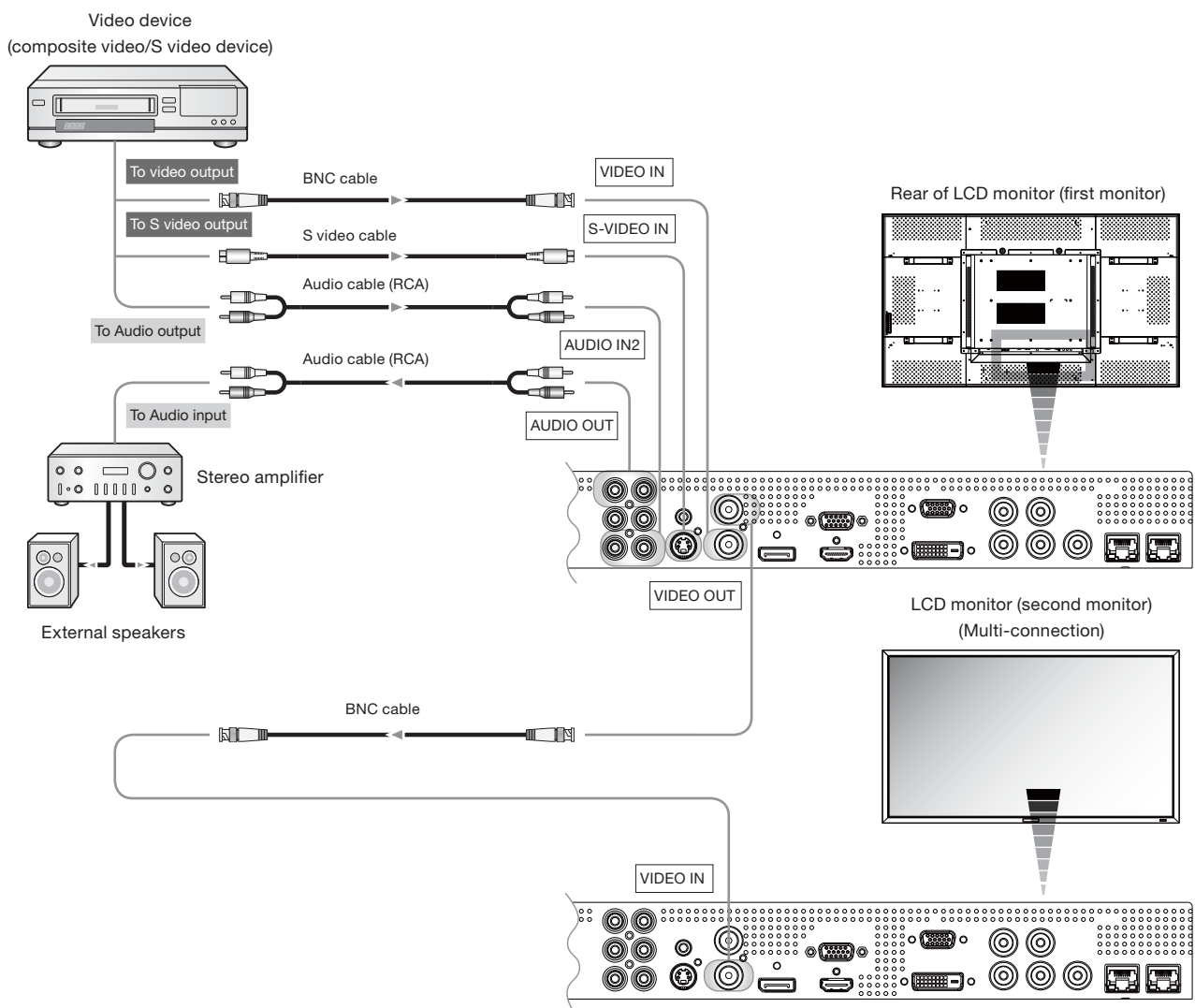

## CAT5 for long-distance connection or multiple-monitor connection

The CAT5 video connection function is for transmitting the analog RGB video signal of the computer and the control signal of the monitor over a long distance using CAT5 cables. The computer can control the monitor via the supplied CAT5 Tx BOX.

### CAUTION:

Never connect network devices (such as a hub and a computer for LAN) to the CAT5 Tx BOX and the IN and OUT connectors of the monitor. If they are connected, the network devices themselves, CAT5 Tx BOX, and monitor may be damaged.

## 1. Installation of the USB driver for CAT5 serial communication control

To connect the computer and the CAT5 Tx BOX via USB interface, it is necessary to install the USB driver to the computer from the CD-ROM supplied with the monitor. (When connecting the computer and the CAT5 Tx BOX via RS-232C interface, you don't have to install the USB driver.)

OS supported: Windows® XP, Windows Vista®

### How to install:

#### 1) Installation to Windows® XP

Start the "PL2303-Driver\_XP2K\_v\*\*\*\*\*.exe" file in the Windows XP folder on the CD-ROM supplied with the monitor and install the driver according to the instructions displayed on the screen.

#### 2) Installation to Windows Vista®

Start the "PL2303\_Prolific\_Vista\_\*\*\*\*\*.exe" file in the Windows VISTA folder on the CD-ROM supplied with the monitor and install the driver according to the instructions displayed on the screen.

### NOTE:

It is unnecessary to install the USB driver if you don't use the communication control or the USB driver. When the window asking you to install the driver is displayed, select cancel. As for the latest driver for the Windows operating system, check the operation of the interface IC "PL-2203" in advance, referring to the website of Prolific Technology Inc. Prolific Technology Inc. and Mitsubishi don't assume any responsibility or liability for any damages incurred by the user.

Operation check by Mitsubishi

- File name: PL2303\_Prolific\_DriverInstaller\_v110.zip, Release date: December 2, 2009, Version: V1.1.0
- Windows XP (32 bits): Operated
- Windows Vista (32 bits): Operated
- Windows 7 (32 bits): Operated

## 2. Connection of the CAT5 video connection function

There are two cases of connection.

### 1) Connection to one monitor

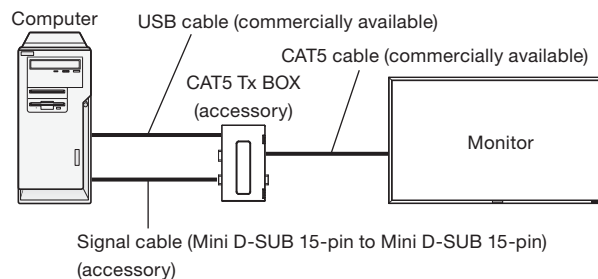

1. Connect the USB connector of the supplied CAT5 Tx BOX and that of the computer using a commercially available USB cable. (When the USB driver isn't available, connect an RS-232C cable in addition to the USB cable. In this case, the RS-232C cable serves for supplying the power to the CAT5 Tx BOX.) See page 36.
2. Connect the RGB input connector (Mini D-SUB 15-pin) of the CAT5 Tx BOX and the D-SUB output connector of the computer using the signal cable (Mini D-SUB 15-pin to Mini D-SUB 15-pin) supplied with the monitor.
3. Connect the CAT5 output connector (Modular connector 8-pin) of the CAT5 Tx BOX and the IN connector of the RGB5/CAT5 input/output connector (Modular connector 8-pin) of the monitor using a commercially available CAT5 cable.

### 2) Connection to multiple monitors

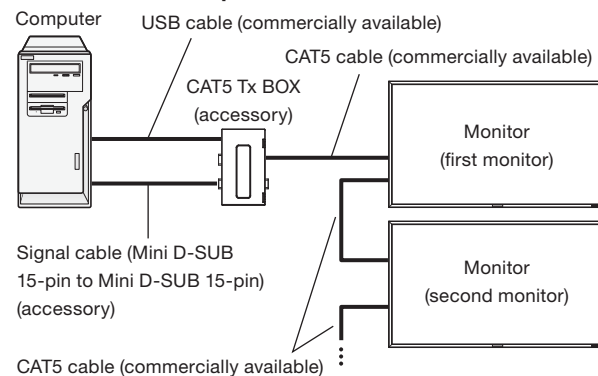

1. In addition to the connection described in 2-1), connect the OUT connector of the RGB5/CAT5 input/output connector (Modular connector 8-pin) of the first monitor and the IN connector of the RGB5/CAT5 input/output connector (Modular connector 8-pin) of the second monitor using a commercially available CAT5 cable.
2. Connect the third and later monitors in the same way. You can connect up to 5 monitors.

**Allowable cable length**

Connection	Max. cable length/signal timing
One monitor	150 m / 1920 x 1080 @60 Hz
Multiple monitors	200 m / 1920 x 1080 @60 Hz (Total length of the connected cables)

The lengths given above are based on the actual measurements using our standard signal source and the recommended cable as follows. Before installation, check the monitor operation in advance by connecting it with your computer and cables.

Recommended cable:

8-pin modular connector, straight-through, shielded, Category 5 or 5e

### **3. Various settings involved in the CAT5 video connection**

In the case of the CAT5 video connection, configure the following settings displayed on the OSD screen. (See page 47.)

#### **1) CAT5 CABLE LENGTH**

Select the cable length, and the defaults of all the adjustment values are automatically determined.

Select the length that is closest to the actual length of your cable.

#### **2) CAT5 EQ.**

Make adjustment so that blur and smear of the displayed letters and graphic objects are minimized.

#### **3) CAT5 RED GAIN/GREEN GAIN/BLUE GAIN**

When the displayed image is dark, increase each value.

When whites aren't displayed as intended, adjust the RED GAIN and BLUE GAIN values.

#### **4) CAT5 RED SKEW/GREEN SKEW/BLUE SKEW**

Adjust each value so that the color deviation in the displayed letters and graphic objects is minimized.

## Monitor control via RS-232C

By connecting multiple LCD monitors and a computer using RS-232C cables (commercially available) or CAT5 cables (commercially available), you can control the monitors from the computer via the supplied CAT5 Tx BOX for the following operations:

- Power ON or OFF
- Switching between input signals

### Connection

**Connection by RS-232C (For RS-232C cable (commercially available), the reverse type cable should be used.)**

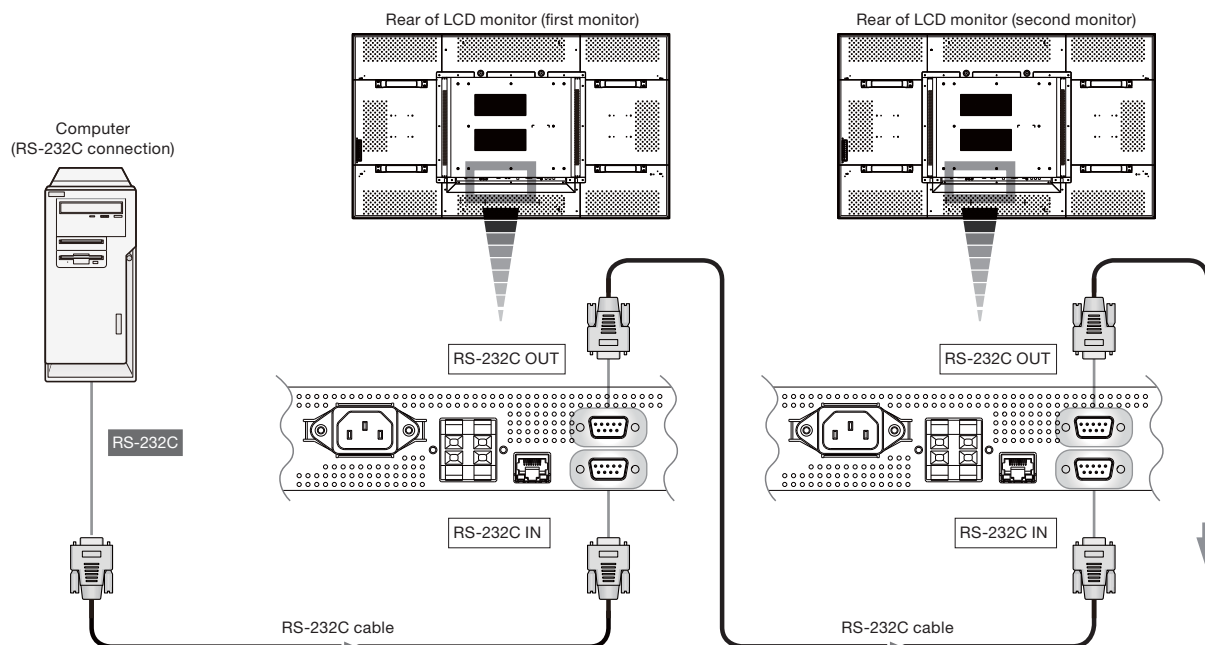

- Before making connections, turn off the personal computer and the monitors.
- Start the personal computer first, and then turn on the monitors. (Otherwise, the com port may be unusable.)

### CAUTION:

Never connect network devices to the CAT5 IN and OUT connectors. If you do so, they may adversely affect with each other, causing breakdown.

### NOTE:

If your PC (IBM or IBM compatible) is equipped only with a 25-pin serial port connector, a 25-pin serial port adapter is required. Contact your dealer for details.

If you use RS-232C control and CAT5 video connection, please switch the input select switch on CAT5 Tx BOX (on page 12) to side "USB" when connecting with USB cable for power supply, or to side "RS232C" when connecting with an auxiliary DC power adapter.

**Monitor connection using LAN**

By connecting the monitor and the computer using a LAN cable (commercially available), you can control the following functions from the computer.

- Power ON or OFF
- Switching between input signals

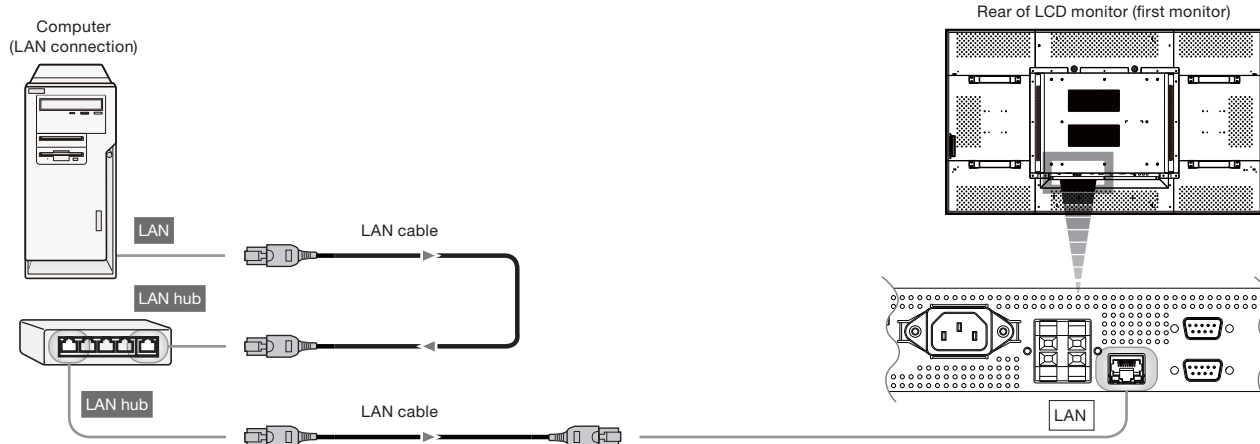

# P-8

# Connecting the power cord to the monitor

## Connecting the power source

- The power outlet socket should be installed as near the equipment as possible and should be easily accessible.
- Fully insert the prongs into the power outlet socket.  
Loose connection may cause noise.

**NOTE:**

Please refer to "Safety Precautions, Maintenance & Recommended Use" in this manual for proper selection of the AC power cord. Use the clamper to prevent accidental disconnection of the power cord.

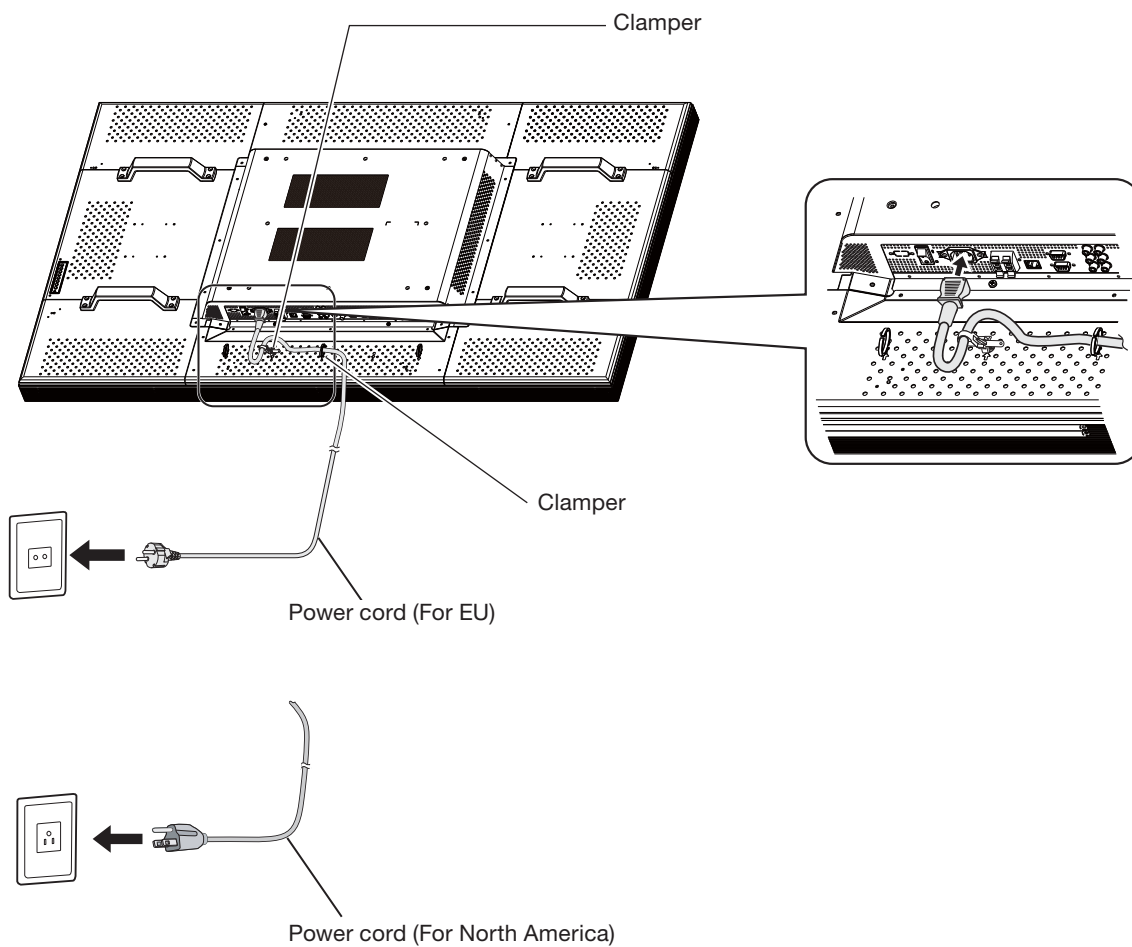

# How to Use

## Flow of How to Using

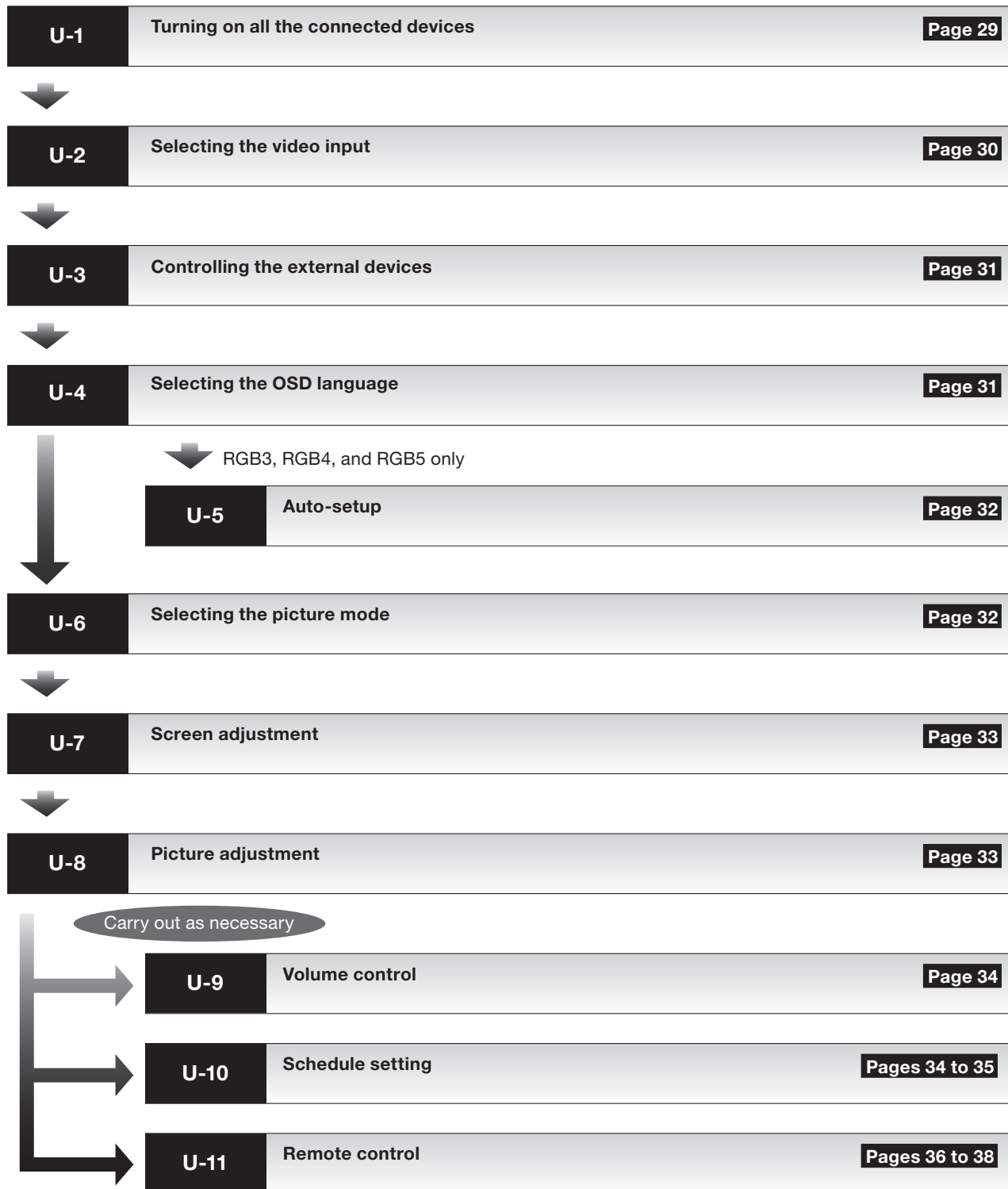



# U-1 Turning on all the connected devices

## Turning on external devices

### 1. Turn on the connected devices such as the computer and VCR.

Before turning on the monitor, turn on the computer.

## Turning on the monitor

### 2. Turn on the Main Power Switch.

The power indicator turns on green.

The control buttons on the rear of the monitor and the wireless remote control don't work while the Main Power Switch is off (the power indicator is off).

When using them, check that the Main Power Switch is on (the power indicator is on).

### 3. When the power indicator glows red, press the POWER button on the monitor.

The power indicator turns green.

## Power Management Function

This function reduces the power consumption of the monitor when the keyboard or the mouse is not used for a fixed period even though the power of the monitor is on.

While this function is working, the screen becomes dark and the power indicator glows green and red.

This function is available only when a computer equipped with the VESA-approved DPM Power Management function is connected to the monitor.

Check that the power management function (power saver) for RGB is ON.

When you turn on this function for VIDEO, the monitor goes into the sleep mode in 10 minutes after DVD/HD, VIDEO<S>, or VIDEO sync signal is lost.

#### [Description]

DPM: Acronym for Display Power Management

#### NOTE:

The default power management settings (power savers) for RGB and VIDEO are ON.

### Power Indicator

Status	LED
Power ON	Green
Power OFF	Red
Power Standby when "SCHEDULE" is enable	Red On Green Blinking
Power Standby	Red, Green
Diagnosis (Detecting failure)	Red Blinking

\* See troubleshooting on page 55.

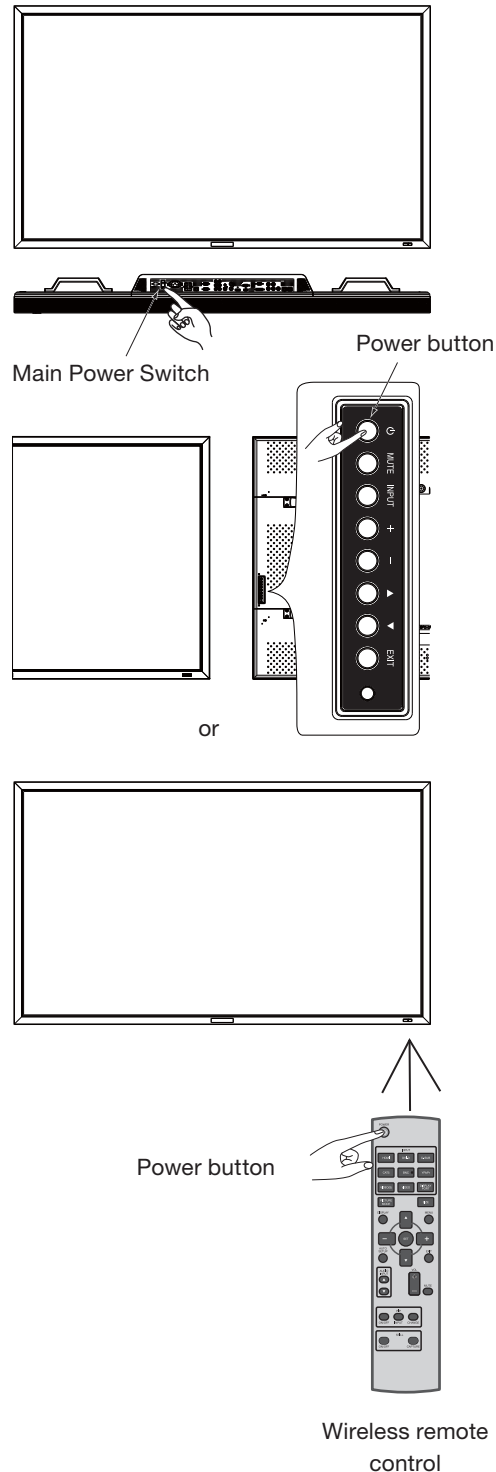

## U-2 Selecting the video input

You can select the desired video input using the wireless remote control or the INPUT button on the monitor.

### ■ Select using the INPUT buttons on the wireless remote control.

You can select the desired video input by pressing the corresponding INPUT button on the wireless remote control.

Selectable video inputs are [RGB1] (HDMI), [RGB2] (DVI-D), [RGB3] (D-SUB), [RGB4] (BNC), [RGB5] (CAT5), [RGB6] (DISPLAY PORT), [DVD/HD] (YPbPr), [VIDEO<S>], and [VIDEO].



### ■ Select using the INPUT button on the monitor.

When you press the INPUT button on the monitor, the video input OSD menu is displayed and you can select the video input using the ▲ and ▼ buttons.

Selectable video inputs are [RGB1] (HDMI), [RGB2] (DVI-D), [RGB3] (D-SUB), [RGB4] (BNC), [RGB5] (CAT5), [RGB6] (DISPLAY PORT), [DVD/HD], [VIDEO-S], and [VIDEO].

#### NOTE:

The selection you make doesn't complete unless you press the INPUT button while the OSD information is displayed. See page 47.

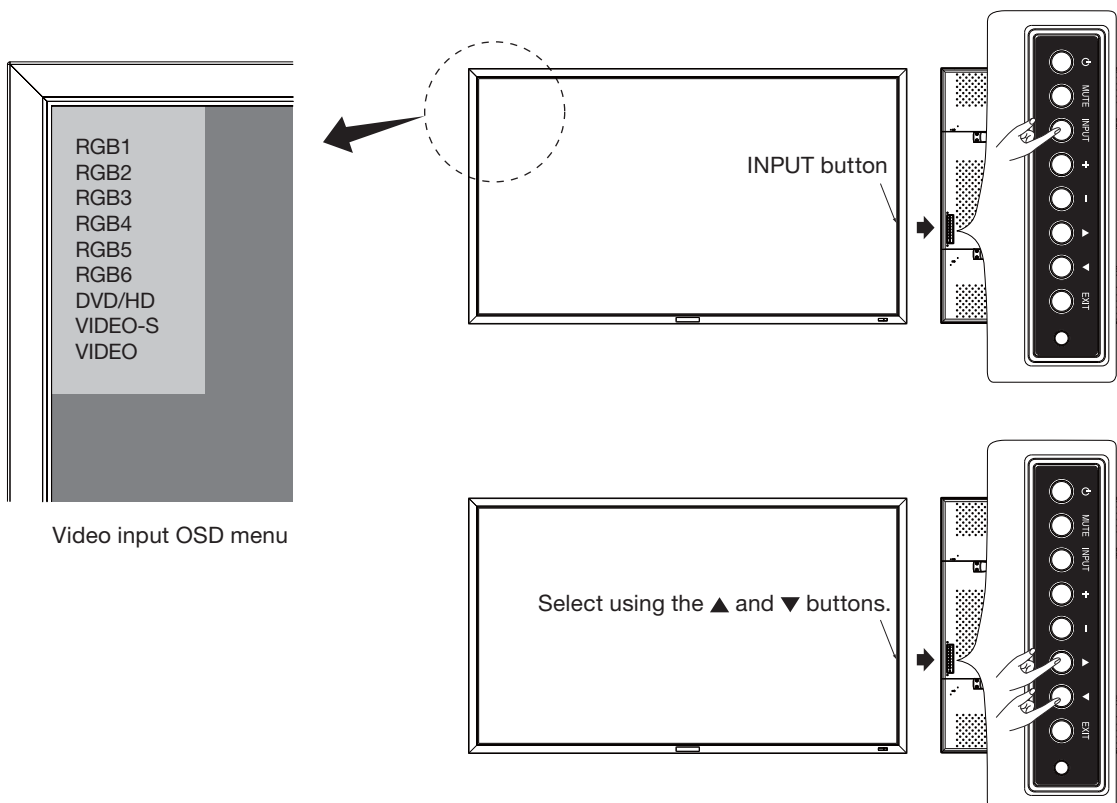

## U-3 Controlling the external devices

---

You can control the externally connected devices to display images supplied from them.

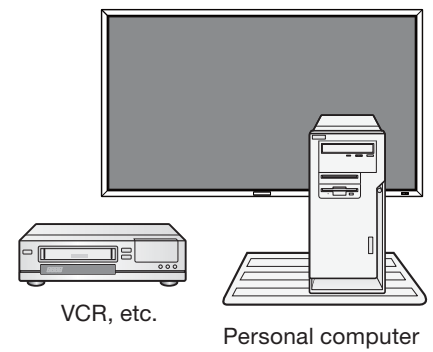

English

## U-4 Selecting the OSD language

---

Select the OSD language using LANGUAGE in the CONFIGURATION1 menu of the OSD screen function. See page 46.

## U-5 Auto-setup

Analog inputs only

The AUTO SETUP button on the wireless remote control or AUTO SETUP in the OSD menu automatically adjusts the screen size, horizontal/vertical position, clock, clock phase, white level, and black level.

### NOTE:

The auto setup works on RGB3, RGB4, and RGB5 only.

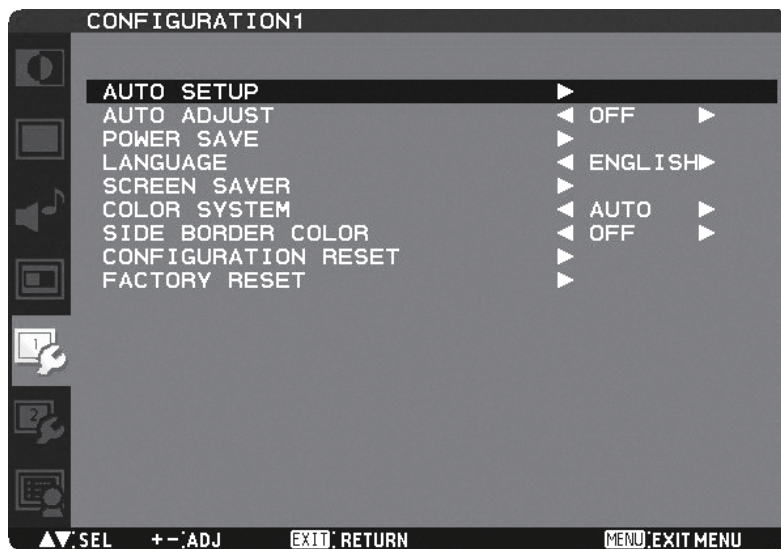
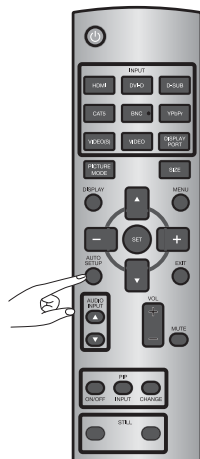

## U-6 Selecting the picture mode

Using the PICTURE MODE button on the wireless remote control, you can select the picture mode suitable for images to be displayed.

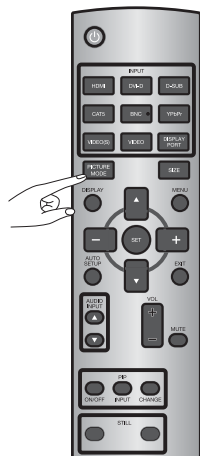

- HIGHBRIGHT: The brightness is maximized.
- STANDARD: Factory default setting.
- sRGB: Suitable for color matching with sRGB-compliant devices.
- CINEMA: Suitable for viewing movies.

## U-7 Screen adjustment

When images aren't displayed properly even after the auto setup, you can alternatively adjust the screen by pressing the MENU button on the wireless remote control or the control buttons on the rear of the monitor to display the OSD menu. Using the SCREEN settings in the OSD menu, you can adjust the horizontal/vertical position, clock, clock phase, zoom mode, CUSTOM ZOOM, horizontal resolution, and vertical resolution.

### NOTE:

The position adjustment works on RGB3, RGB4, DVD/HD, VIDEO<S>, and VIDEO only.

The clock adjustment and the resolution adjustment work on RGB3 and RGB4 only.

The zoom adjustment works on all video inputs.

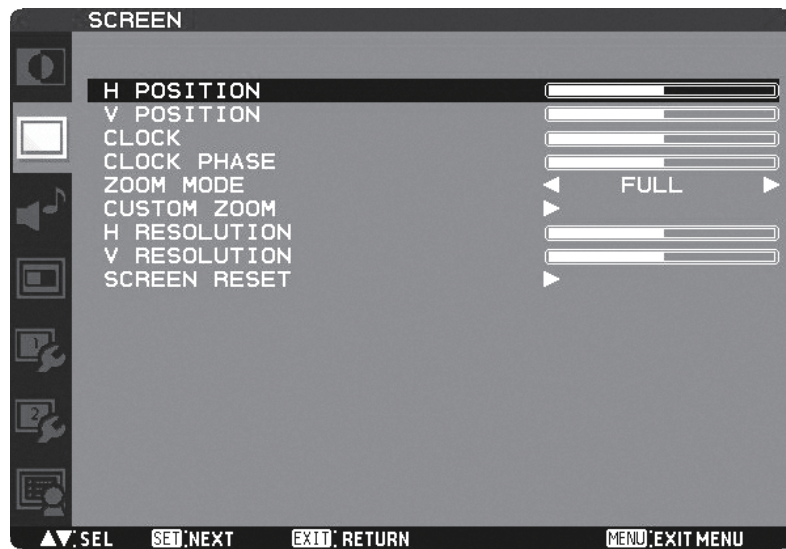

## U-8 Picture adjustment

You can adjust the picture by pressing the MENU button on the wireless remote control or the control buttons on the rear of the monitor to display the OSD menu.

Using the PICTURE settings in the OSD menu, you can adjust picture settings such as the brightness, contrast, and sharpness.

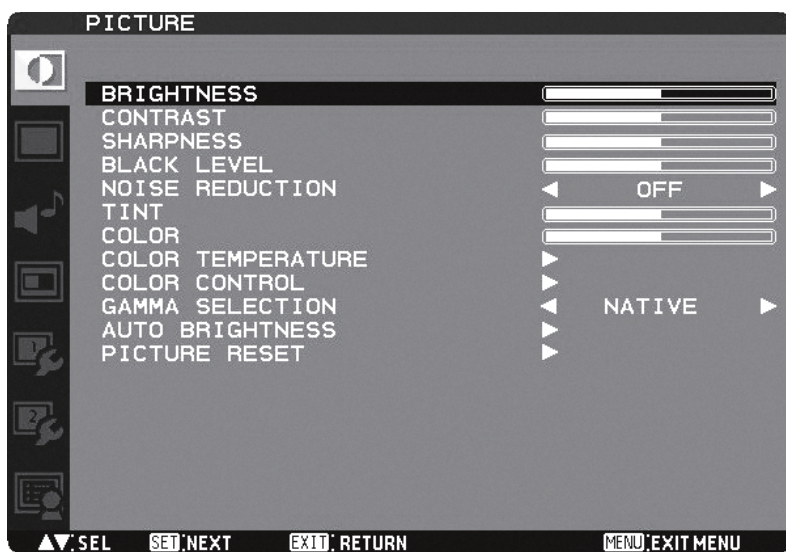

## U-9 Volume control

Carry out as necessary

When outputting audio from the option stereo speakers, you can control the volume level using the VOL button on the wireless remote control.

In addition, you can adjust the volume by pressing the MENU button on the wireless remote control or the control buttons on the rear of the monitor to display the OSD menu. Using the AUDIO settings in the OSD menu, you can adjust the balance, treble, and bass.



Volume control



Displaying the OSD menu

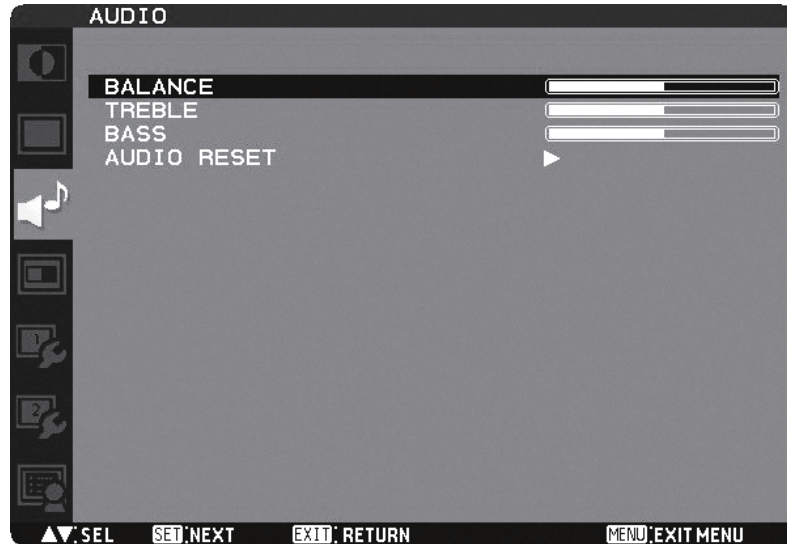

## U-10 Schedule setting

Carry out as necessary

You can program the power-on/off and input selection using the SCHEDULE setting in the OSD menu that is displayed by pressing the MENU button on the wireless remote control or the control buttons on the rear of the monitor.

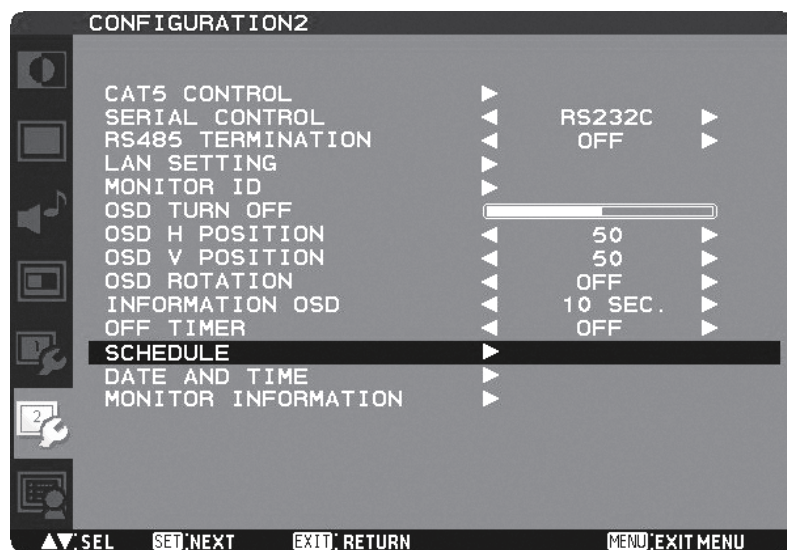
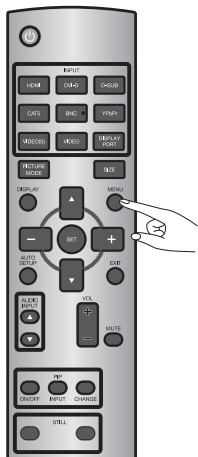

**How to set up schedule**



When the cursor is on any of the check boxes showing the program numbers 1 to 7 on the left side of the screen, pressing the UP (▲) or DOWN (▼) button moves the cursor vertically and pressing the PLUS (+) or MINUS (-) buttons moves it horizontally. By pressing the SET button, you can select or deselect the check boxes.

**Check box:** When the check box is selected, the program is enabled. When it is cleared, the program is disabled. When the SCHEDULE screen is closed, the programs you made become enabled and will be executed at the specified times.

When the cursor is on any item of the schedule settings in the white frame, pressing the PLUS (+) button moves it to the right and pressing the MINUS (-) button moves it to the left.

You can set the power-on/off time and video input by pressing the UP (▲) or DOWN (▼) button. You can select or deselect the radio buttons by pressing the SET button.

- ON:** Set the time when the power is turned on. If you don't want to set the power-on time, enter "--."
- OFF:** Set the time when the power is turned off. If you don't want to set to the power-off time, enter "--."
- INPUT:** Set the video input to be selected when the power is turned on. If you want to select the vide input that was selected before the power is turned on, enter "--."
- EVERY DAY:** Select this option to execute the schedule every day. When you select EVERY DAY, you cannot select any days of the week and EVERY WEEK.
- MON - SUN:** Select the days of the week on which you want to execute the schedule. Unless you select EVERY WEEK, too, the selection of the days of the week is cleared after the schedule is executed one time.
- EVERY WEEK:** Select this option to execute the schedule on the selected days of the week, every week.

**NOTE:**

- Before making the schedule settings, be sure to check the current date and time using "DATE AND TIME."
- When you close the SCHEDULE screen, the settings are saved.
- When two or more schedules are enabled, they are executed in descending order of the program number, and the power is turned off upon completion of the last executed schedule.
- When there are two or more schedules having the same power-on/off time, the one having the largest program number is executed.
- You cannot set the power-on time and the power-off time to the same time.
- When OFF TIMER is ON, the schedule settings are ignored.

## RS-232C/RS-485 Remote control

By connecting multiple LCD monitors and a computer using RS-232C cables (commercially available) or CAT5 cables (commercially available), you can control the monitors from the computer via the supplied CAT5 Tx BOX for the following operations:

- Power ON or OFF
- Switching between input signals
- Volume control and mute
- Auto setup

### Connection

**Connection by RS-232C (For RS-232C cable (commercially available), the reverse type cable should be used.)**

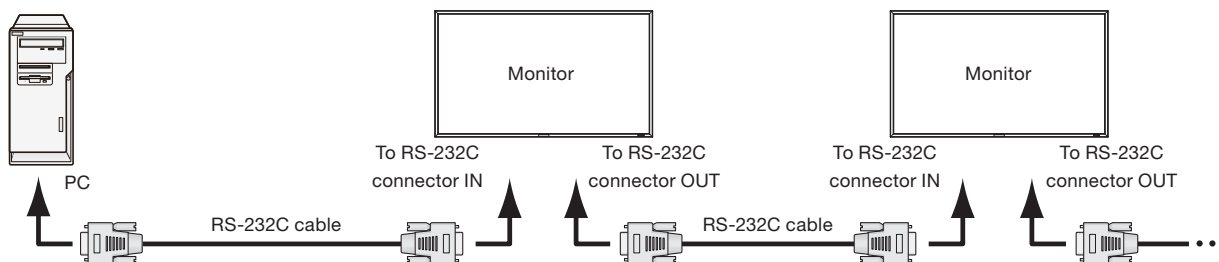

**Connection by CAT5 RS-485 (For CAT5 cable (commercially available), the straight type cable should be used)**

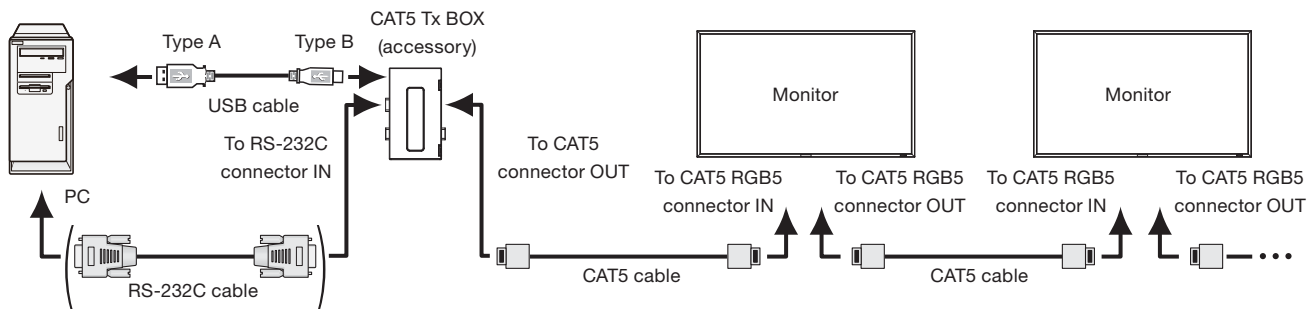

\* This connection isn't necessary when the USB COM port is used.

- Before making connections, turn off the personal computer and the monitors.
- Start the personal computer first, and then turn on the monitors. (Otherwise, the com port may be unusable.)

### NOTE:

For connection with a 25-pin serial port connector on the computer, a conversion adapter (commercially available) is required.

#### 1) Interface

PROTOCOL	RS-232C/RS-485 (CAT5)
BAUD RATE	9600 [bps]
DATA LENGTH	8 [bit]
PARITY BIT	NONE
STOP BIT	1 [bit]
FLOW CONTROL	NONE

This LCD monitor uses RXD, TXD and GND lines for RS-232C control.

CAT5 Tx BOX uses RXD, TXD, DTR, and GND lines for RS-485 control with RS-232C connector.

Because the communication system of RS-485 is a half duplex, CAT5 Tx BOX uses RXD, TXD, and RTS lines for RS-485 control with USB connector.



## 2) Control command diagram

The command is structured by the address code, function code, data code and end code. The length of the command is different for each function.

**NOTE:**

This example shows a basic command that is used when a single computer and a single monitor are connected.

When you want to connect multiple monitors or perform complicated control using other commands than the basic commands, contact your dealer for advanced command specifications.

	Address code	Function code	Data code	End code
HEX	30h 30h	Function	Data	0Dh
ASCII	'0' '0'	Function	Data	↵

[Address code] 30h 30h (ASCII code, '0' '0'), fixed.

[Function code] Code unique to each control function.

[Data code] Data unique to each control function (Not always indicated by numerical values.)

[End code] 0Dh (In ASCII code, '↵') fixed.

## 3) Control sequence

- (1) A command is sent from the computer to the monitor. (Commands should be sent at intervals of at least 600 ms.)
- (2) The monitor sends a return command within 600 ms\* after receiving and encoding the command. If the monitor fails to receive the command, it doesn't send any return command.
- (3) The computer checks the return command to see that the command it sent was executed or not.
- (4) The monitor sends various codes other than the return code. While RS-232C control sequence is in progress, reject other codes on the personal computer side.

\*: Transmission of the return command may be delayed during signal switchover, etc.

Example: Turn the power ON (' ' is for ASCII code)

Command from computer	Command from monitor	Detail of command
30 30 21 0D '0' '0' '!' '↵'		Command for POWER ON
	30 30 21 0D '0' '0' '!' '↵'	Command received (Command echoed back)

For RS-485, both of DTR and RTS lines remain Active Low while the TXD command is sent from the computer.

## 4) Operation commands

The operation commands configure the basic operation settings of this LCD monitor. The commands may not work during signal switchover.

The operation commands have no data codes.

Operation	ASCII	HEX
POWER ON	!	21h
POWER OFF	"	22h
INPUT RGB 1	_r1	5Fh 72h 31h
INPUT RGB 2	_r2	5Fh 72h 32h
INPUT RGB 3	_r3	5Fh 72h 33h
INPUT RGB 4	_r4	5Fh 72h 34h
INPUT RGB 5	_r5	5Fh 72h 35h
INPUT RGB 6	_r6	5Fh 72h 36h
INPUT VIDEO	_v1	5Fh 76h 31h
INPUT DVD/HD	_v2	5Fh 76h 32h
INPUT S-VIDEO	_v3	5Fh 76h 33h
VOLUME UP	r06	72h 30h 36h
VOLUME DOWN	r07	72h 30h 37h
MUTE	ra6	72h 61h 36h
AUTO SETUP	r09	72h 30h 39h

- POWER OFF command should be operated over 1 minute after the power is turned on.
- POWER ON command should be operated over 1 minute after the power is turned off.
- After sending any of the video input selection commands, wait for at least 10 seconds to send the next command.

### 5) Read command

The computer sends the command without datacode to the monitor.

After receiving this command, the monitor returns the command with datacode including the current status to the computer.

Example: When the computer asks the power status of the monitor, and the status of the monitor is powered-on.

Command from computer	Command from monitor	Detail of command
30 30 76 50 0D '0''0''v''P'[enter]		Ask about the power status of the monitor.
	30 30 76 50 31 0D '0''0''v''P''1'[enter]	Monitor is powered-on.

#### Structure of the Read-command

			ASCII		HEX	
			Function	Data (Receive)	Function	Data (Receive)
POWER	ON		vP	1	76 50	31
	OFF (stand by)		vP	0	76 50	30
Input	RGB-1 (HDMI)		vl	r1	76 49	72 31
	RGB-2 (DVI-D)		vl	r2	76 49	72 32
	RGB-3 (D-SUB)		vl	r3	76 49	72 33
	RGB-4 (BNC)		vl	r4	76 49	72 34
	RGB-5 (CAT5)		vl	r5	76 49	72 35
	RGB-6 (DISPLAY PORT)		vl	r6	76 49	72 36
	Video		vl	v1	76 49	76 31
	DVD/HD		vl	v2	76 49	76 32
S-VIDEO		vl	v3	76 49	76 33	
Internal temperature	Around the main board	Resolution 1°C	tc1	(ex.) +25	74 63 31	2B 20 32 35
	Around the power supply	Resolution 1°C	tc2	(ex.) +31	74 63 32	2B 20 33 31

## LAN Remote control

By connecting the monitor and the computer using a network device such as a LAN hub as shown in Section P-7 and making the network settings using the OSD menu and RS-232C communication control, you can perform remote control using the same commands as those for RS-232C.

### 1. Setting procedure

- (1) Set the following network parameters using the OSD menu. (See page 47.)
  - ON/OFF, IP address, subnet mask, gateway mask setting, and default gateway of DHCP client
- (2) Send the same control command as that for RS-232C via TCP/IP socket communication.
- (3) Check the status sent from the monitor. When it is received successfully, the setting is completed.

# Configuration and basic operation of OSD screen

## Configuration of OSD screen

This monitor is equipped with the OSD (On Screen Display) function for easy screen adjustment. The OSD function allows you to control the menus displayed on the screen for brightness setting and other settings. The OSD screen is configured as shown below.

### Main Menu Screen

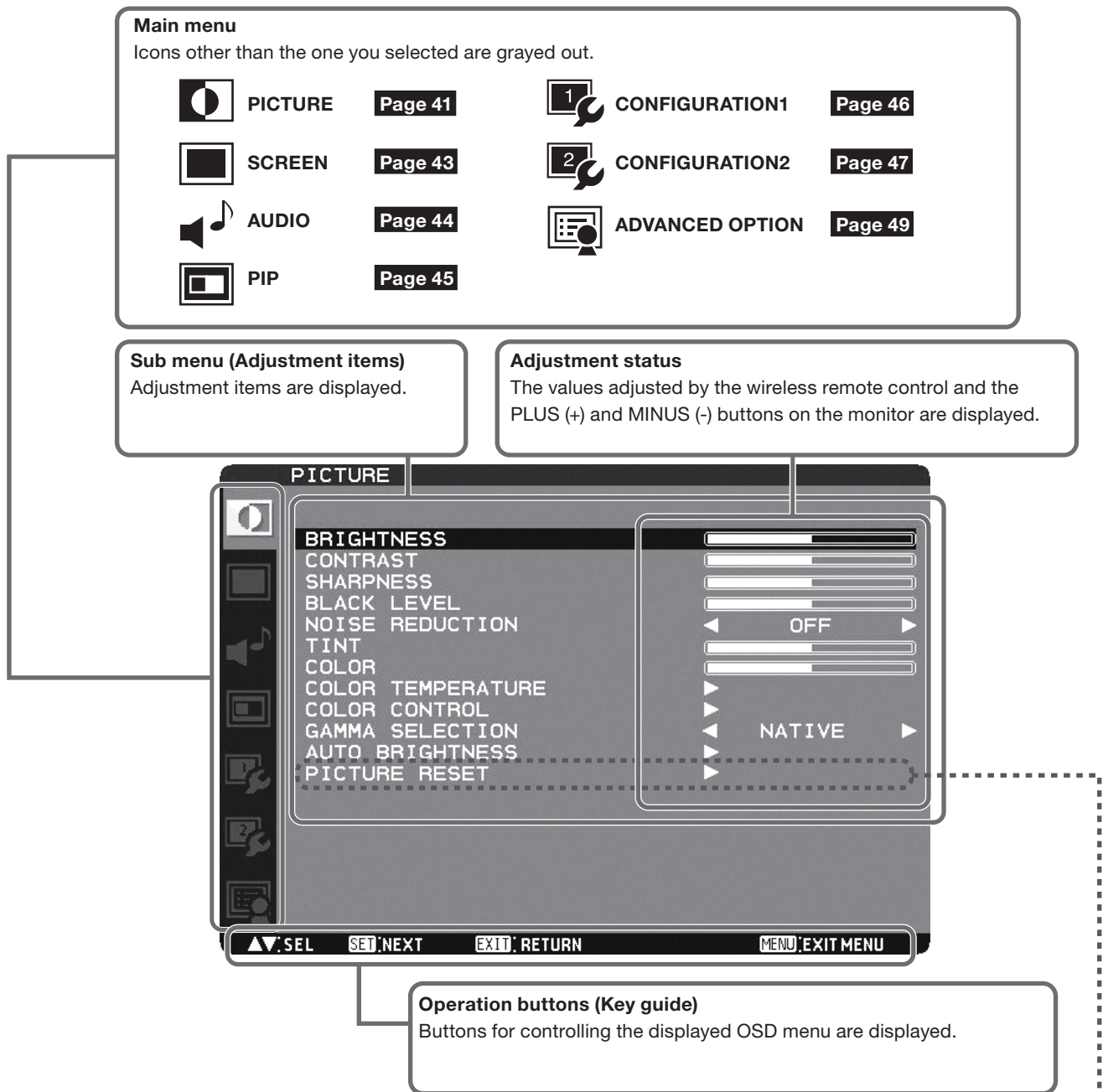

### Sub menu screen

When you select a sub menu, an OSD screen is displayed. Sub menus contain information screens, adjustment menu screens, and selection menu screens as shown below.



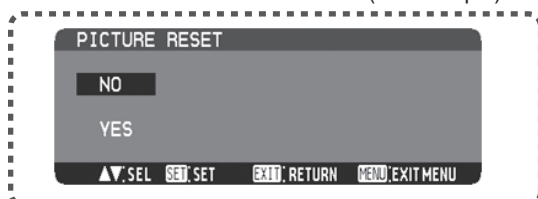

Sub menu screen: Picture reset (for example)

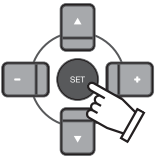
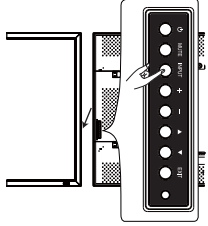

# Configuration and basic operation of OSD screen (continued)

## Basic operation of OSD

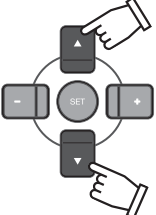
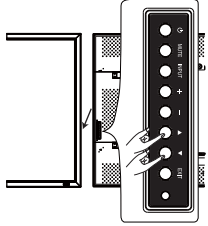
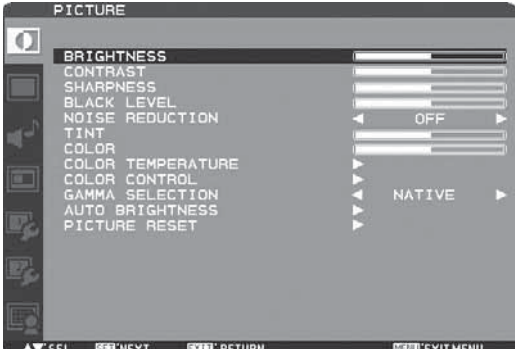
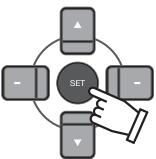
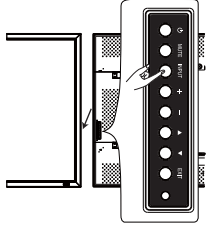
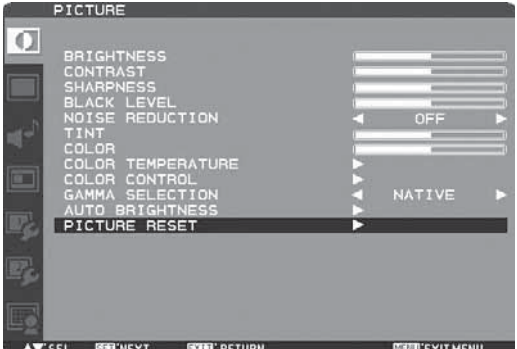
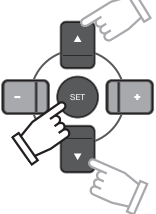
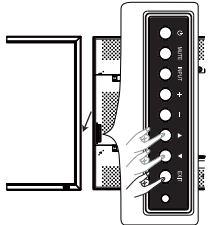
When the MENU button on the wireless remote control or the EXIT button on the monitor is pressed, the OSD screen is displayed. Select a main menu by pressing the ▲ or ▼ button.

Wireless remote control	Monitor button	OSD screen
 <p>Accept the selected main menu by pressing the SET button.</p>	 <p>Select a main menu by pressing the INPUT button.</p>	
 <p>Select a sub menu by pressing the ▲ or ▼ button.</p>	 <p>Select a sub menu by pressing the ▲ or ▼ button.</p>	
 <p>Accept the selected sub menu by pressing the SET button.</p>	 <p>Accept the selected sub menu by pressing the INPUT button.</p>	
 <p>Select the setting value by pressing the ▲ or ▼ button and then press the SET button to accept the setting.</p>	 <p>Select the setting value by pressing the ▲ or ▼ button and then press the INPUT button to accept the setting.</p>	

The OSD screen disappears when you press the MENU button on the wireless remote control once or the EXIT button on the monitor three times.

# OSD screen functions

## PICTURE

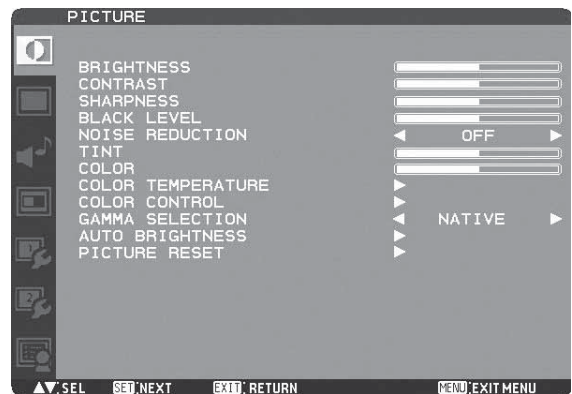

### ■ BRIGHTNESS

You can adjust the brightness.

Press the PLUS (+) button to increase the brightness. Press the MINUS (-) button to decrease the brightness.

### ■ CONTRAST

You can adjust the contrast.

Adjust the contrast using the PLUS (+) or MINUS (-) button to obtain a desired result.

### ■ SHARPNESS

You can adjust the sharpness.

Press the PLUS (+) button to make the image look sharper. Press the MINUS (-) button to make the image look softer.

NOTE: If you increase the sharpness setting value too much, lines may appear double. In such a case, decrease the sharpness setting value.

### ■ BLACK LEVEL

You can adjust the brightness in the dark area of the image. Press the PLUS (+) button to brighten dark areas in the image. Press the MINUS (-) button to further darken the dark area of the image.

NOTE: This adjustment doesn't work in the sRGB picture mode.

### ■ NOISE REDUCTION

\* For the VIDEO<S> and VIDEO inputs only.

You can adjust the noise reduction level.

Press the PLUS (+) button to increase the value to lessen the noise.

### ■ TINT

\* For the RGB1, DVD/HD, VIDEO<S>, and VIDEO inputs only.

When you select TINT by pressing the SET button on the wireless remote control, the TINT screen appears and you can adjust the following.

[TINT]:

You can adjust all the colors at the same time. Press the PLUS (+) button to add a green tint. Press the MINUS (-) button to add a purple tint.

[RED], [MAGENTA], [BLUE], [CYAN], [GREEN], or [YELLOW]:

You can adjust each color individually. Press the PLUS (+) button to shift the selected color to the right around the color circle. Press the MINUS (-) button to shift the selected color to the left around the color circle.

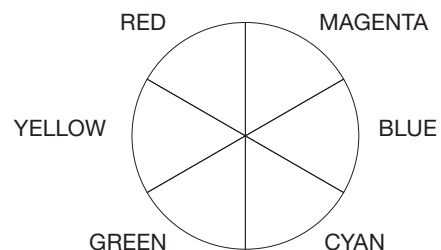

Color circle

### ■ COLOR

\* For the RGB1, DVD/HD, VIDEO<S>, and VIDEO inputs only.

When you select COLOR by pressing the SET button on the wireless remote control, the COLOR screen appears and you can adjust the following.

[COLOR]:

You can adjust all the colors at the same time. Press the PLUS (+) button to deepen the colors. Press the MINUS (-) button to lighten the colors.

[RED], [MAGENTA], [BLUE], [CYAN], [GREEN], or [YELLOW]:

You can adjust each color individually. Press the PLUS (+) button to deepen the selected color. Press the MINUS (-) button to lighten the selected color.

NOTE: This adjustment doesn't work in the sRGB picture mode.

### ■ COLOR TEMPERATURE

You can adjust the color temperature.

The image becomes reddish as the color temperature decreases, and it becomes bluish as the color temperature increases.

NOTE: This adjustment doesn't work in the sRGB picture mode.

### ■ COLOR CONTROL

The color levels of red, green, and blue are adjusted by the color bars.

R: Red, G: Green, B: Blue

### ■ GAMMA SELECTION

You can select the gamma mode from NATIVE, S GAMMA, 2.2, 2.4 and OPTION.

NOTE: GAMMA is fixed to 2.2 in the sRGB picture mode.

## OSD screen functions (continued)

---

### ■ AUTO BRIGHTNESS

This function controls the screen brightness depending on the ambient light for easy viewing.

In addition, it changes the screen brightness depending on the ambient light and what are displayed on the screen to reduce power consumption as low as possible.

#### [AUTO BRIGHTNESS]

LOCAL: The auto brightness function is enabled.

REMOTE: The auto brightness function is enabled.

In addition, the monitor enters the intercommunication mode where multiple monitors are controlled collectively. (See page 52.)

OFF: This function is disabled.

#### [CONTROL]

PRIMARY: Select this setting to configure the monitor as Master when controlling multiple monitors collectively.

SECONDARY: Select this setting to use the monitor alone or to configure the monitor as Slave when controlling multiple monitors collectively.

#### [LIGHT FROM BACK]

YES: Select this setting when there is a light source such lighting equipment and a window behind the monitor.

NO: Select this setting when there is no light source such lighting equipment and a window behind the monitor.

#### [BACK WALL]

Select the following settings according to the distance between the rear of the monitor and the wall or window.

FAR: The distance is 5 meters or longer.

NEAR: The distance is 5 meters or shorter.

#### [FRONT SENSOR]

Select ON for normal use.

OFF: Select this setting when the sensor on the front panel is shielded.

#### [REAR SENSOR]

Select ON for normal use.

OFF: Select this setting when the sensor on the rear panel is shielded.

#### [SATURATION]

ON: The image saturation is adjusted depending on the ambient light.

OFF: Image saturation isn't adjusted.

#### [VIDEO DETECT]

ON: The screen brightness varies depending on what are displayed on the screen to reduce power consumption of the monitor.

OFF: The screen brightness doesn't vary and the power consumption isn't reduced.

### ■ PICTURE RESET

You can reset all the PICTURE settings to the factory defaults.

# OSD screen functions (continued)

## SCREEN

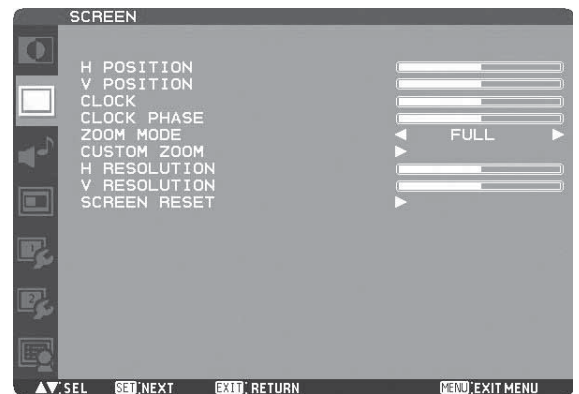

### ■ H POSITION

You can adjust the horizontal image position.  
Press the PLUS (+) button to move the image to the right.  
Press the MINUS (-) button to move the image to the left.

### ■ V POSITION

You can adjust the vertical image position.  
Press the PLUS (+) button to move the image up. Press the MINUS (-) button to move the image down.

### ■ CLOCK

\* For the RGB3 and RGB4 inputs only.  
You can adjust the image size of the computer and eliminate blurred letters.  
Press the PLUS (+) button to expand the width of the image on the screen to the right. Press the MINUS (-) button to narrow the width of the image on the screen to the left.

### ■ CLOCK PHASE

\* For the RGB3 and RGB4 inputs only.  
You can adjust the level of the periodic variation of the screen flicker.

### ■ ZOOM MODE

You can select the mode to stretch the image to fit it to the screen.  
For the RGB1, RGB2, RGB3, RGB4, RGB5, and RGB6 inputs, you can select FULL, NORMAL, CUSTOM, or REAL.  
For DVD/HD, VIDEO<S>, and VIDEO, you can select FULL, NORMAL, DYNAMIC, CUSTOM, or REAL.  
FULL: The image is stretched to fill the screen regardless of its aspect ratio.  
NORMAL: The image is stretched vertically to the full height of the screen while keeping the aspect ratio.  
DYNAMIC: The image is stretched to fill the screen with different magnifications at the screen center and the screen edges.  
CUSTOM: You can stretch the image horizontally and vertically as you desire using the CUSTOM ZOOM setting.  
REAL: The image is displayed without being stretched or reduced.

NOTE: In the DYNAMIC mode, the top and the bottom of the image may be cropped. Full HD images are displayed as in the FULL mode.

### ■ CUSTOM ZOOM

CUSTOM ZOOM becomes selectable when you set ZOOM MODE to CUSTOM.  
ZOOM: You can expand the horizontal and vertical sizes simultaneously.  
H ZOOM: You can expand the horizontal size only.  
V ZOOM: You can expand the vertical size only.  
H POSITION: Pressing the PLUS (+) button moves the image to the right. Pressing the MINUS (-) button moves the image to the left.  
V POSITION: Pressing the PLUS (+) button moves the image up. Pressing the MINUS (-) button moves the image down.

### ■ H RESOLUTION

\* For the RGB3 and RGB4 inputs only.  
Use this setting when AUTO SETUP and AUTO ADJUST cannot obtain the horizontal resolution of the image supplied from an external device.  
Press the PLUS (+) button to increase the resolution. Press the MINUS (-) button to decrease the resolution.

### ■ V RESOLUTION

\* For the RGB3 and RGB4 inputs only.  
Use this setting when AUTO SETUP and AUTO ADJUST cannot obtain the vertical resolution of the image supplied from an external device.  
Press the PLUS (+) button to increase the resolution. Press the MINUS (-) button to decrease the resolution.

### ■ SCREEN RESET

You can reset all the SCREEN settings to the factory defaults.

## OSD screen functions (continued)

---

### AUDIO



#### ■ BALANCE

You can adjust the balance of the right and left volumes.  
Press the PLUS (+) button to decrease the left volume.  
Press the MINUS (-) button to decrease the right volume.

#### ■ TREBLE

You can adjust the high frequency sound.  
Press the PLUS (+) button to increase the treble sound.  
Press the MINUS (-) button to decrease the treble sound.

#### ■ BASS

You can adjust the low frequency sound.  
Press the PLUS (+) button to increase the bass sound.  
Press the MINUS (-) button to decrease the bass sound.

#### ■ AUDIO RESET

You can reset all the AUDIO settings to the factory defaults.



## OSD screen functions (continued)

### PIP (PICTURE IN PICTURE)

#### NOTE:

The PIP and POP functions don't work in the CUSTOM and REAL picture size modes.

Refer to "PIP, POP function" for details. (See page 53.)

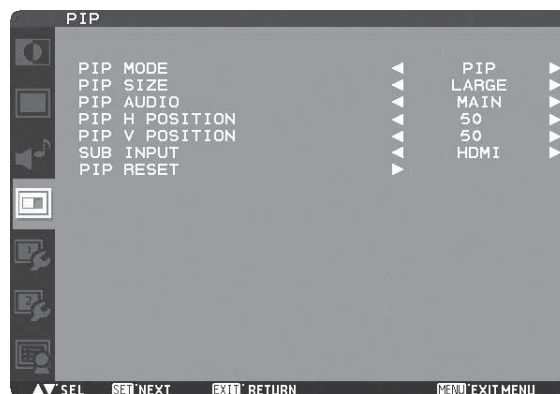

#### ■ PIP MODE

You can select the PIP mode from PIP, POP, SBS ASPECT, SBS FULL, and OFF using the PLUS (+) and MINUS (-) buttons. See page 53.

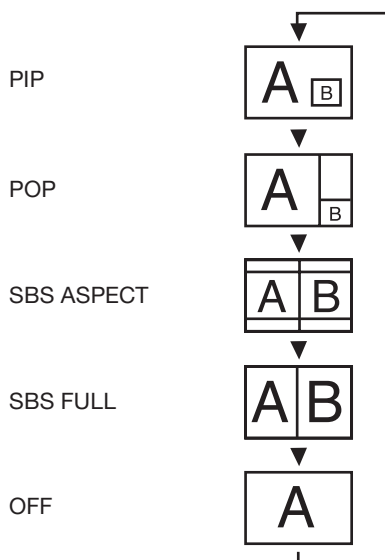

\* SBS: SIDE BY SIDE

#### ■ PIP SIZE

You can select the size of the sub picture displayed in the PIP mode.

You can move the sub picture by pressing the UP (▲), DOWN (▼), PLUS (+), and MINUS (-) buttons.

#### ■ PIP AUDIO

You can select the audio output in the PIP mode.

When MAIN is selected, audio of the main picture is output.

When SUB is selected, audio of the sub picture is output.

#### ■ PIP H POSITION

You can adjust the horizontal position of the sub screen.

Press the PLUS (+) button to move the sub screen to the right. Press the MINUS (-) button to move the sub screen to the left.

#### ■ PIP V POSITION

You can adjust the vertical position of the sub screen.

Press the PLUS (+) button to move the sub screen up. Press the MINUS (-) button to move the sub screen down.

#### ■ SUB INPUT

You can select the video input for the sub screen from HDMI (RGB1), DVI-D (RGB2), D-SUB (RGB3), RGB4, DVD/HD, VIDEO<S>, and VIDEO.

#### ■ PIP RESET

You can reset all the PIP settings to the factory defaults.

# OSD screen functions (continued)

## CONFIGURATION1

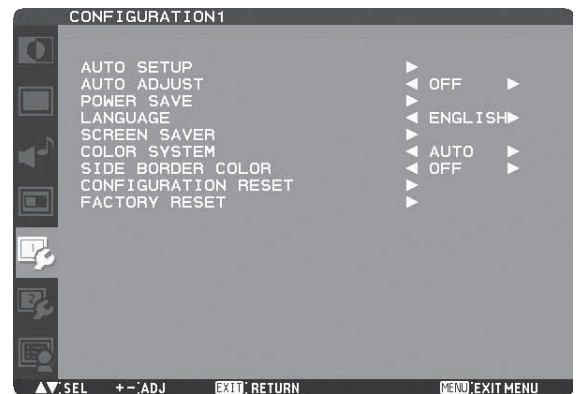

### ■ AUTO SETUP

\* For the RGB3 and RGB4 inputs only.

Press the SET button to automatically adjust the screen size, horizontal position, vertical position, clock, clock phase, white level, and black level.

### ■ AUTO ADJUST

\* For the RGB3 and RGB4 inputs only.

When AUTO ADJUST is ON, the horizontal position, vertical position, and clock phase are automatically adjusted at the time of the timing switching.

### ■ POWER SAVE

When you select ON, the power management function (power save) is activated.

When the RGB1, RGB2, RGB3, RGB4, RGB5, or RGB6 input is selected, the monitor goes into the sleep mode in several seconds after the sync signal is lost.

When the DVD/HD or VIDEO input is selected, the monitor goes into the sleep mode in about 10 minutes after the input signal is lost.

### ■ LANGUAGE

OSD control menus are available in eight languages. (English, German, Spanish, French, Italian, Swedish, Chinese, and Japanese)

### ■ SCREEN SAVER

You can set the SCREEN SAVER functions to reduce the risk of "image persistence."

**GAMMA:**

When you select ON, the gamma mode where image persistence is difficult to occur is used.

**COOLING FAN:**

When you select ON, the cooling fan always runs.

When you select AUTO, the built-in fan automatically starts running according to the operating temperature.

**BRIGHTNESS:**

When you select ON, the brightness decreases.

**MOTION:**

The screen slightly moves horizontally and vertically at regular intervals to reduce the effect of the image persistence.

**NOTE:** When you select a time period in the MOTION setting, the monitor enlarges the image and moves it horizontally and vertically. The portions of the image out of the display area aren't visible.

To make the entire image visible all the time, arrange it to fit within 90% of the screen area at the center.

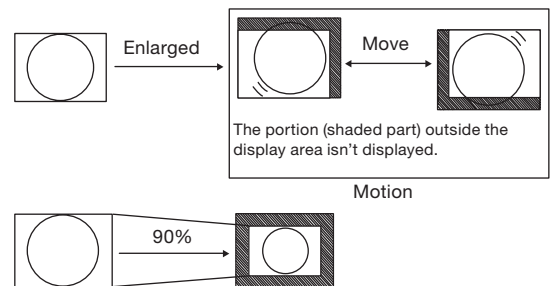

### ■ COLOR SYSTEM

\* For the VIDEO<S> and VIDEO inputs only.

You can select the color system depending on the video device you use.

**AUTO:** NTSC, PAL, SECAM, PAL60 or 4.43 NTSC is automatically selected.

**NTSC:** NTSC

**PAL:** PAL

**SECAM:** SECAM

**4.43NTSC:** 4.43 NTSC

**PAL-60:** PAL60

**NOTE:** When you use a video device purchased from overseas, set the COLOR SYSTEM menu.

### ■ SIDE BORDER COLOR

You can adjust the brightness of the black areas displayed on both sides of 4:3 images.

### ■ CONFIGURATION RESET

You can reset all the CONFIGURATION1 and CONFIGURATION2 settings to the factory defaults.

Note that you cannot reset the setting of LANGUAGE, MONITOR ID, SCHEDULE, and DATE AND TIME.

### ■ FACTORY RESET

You can reset all the settings of PICTURE, SCREEN, AUDIO, CONFIGURATION1, CONFIGURATION2, and ADVANCED OPTION to the factory defaults.

Note that you cannot reset the settings of LANGUAGE and DATE AND TIME.

# OSD screen functions (continued)

## CONFIGURATION2

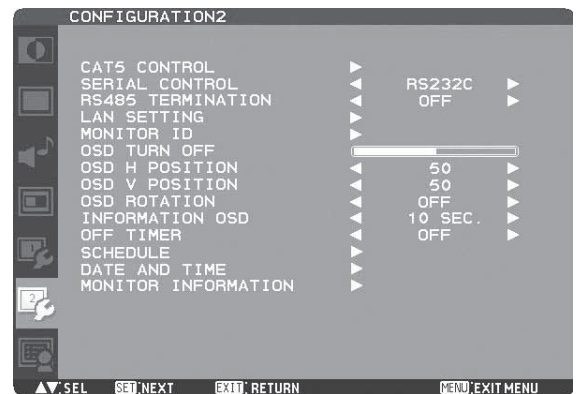

### ■ CAT5 CONTROL

#### [CAT5 CABLE LENGTH]

Select the cable length, and the defaults of all the adjustment values are automatically determined. Select the length that is closest to the actual length of your cable.

#### [CAT5 EQ.]

Make adjustment so that blur and smear of the displayed letters and graphic objects are minimized.

#### [CAT5 RED GAIN, GREEN GAIN, BLUE GAIN]

When the displayed image is dark, increase each value. When whites aren't displayed as intended, adjust the RED GAIN and BLUE GAIN values.

NOTE: Before performing the color adjustment described above, check the TINT settings on page 41.

#### [CAT5 RED SKEW, GREEN SKEW, BLUE SKEW]

Adjust each value so that the color deviation in the displayed letters and graphic objects is minimized.

### ■ SERIAL CONTROL

Select the communication interface (RS-232C or LAN) for the serial communication function.

For connection of the signal cable, see page 36.

### ■ RS485 TERMINATION

Turn ON or OFF the termination resistance of the RS-485 interface.

ON: Select this setting to use the monitor alone or to configure the monitor as the one at the end of the connection when more than one monitor is multi-connected.

OFF: Select this setting to configure the monitor as other than the one at the end of the connection when more than one monitor is multi-connected.

### ■ LAN SETTING

#### DHCP CLIENT

Select whether to use DHCP client or not. Select OFF when not using it, and select ON when using it.

#### IP ADDRESS

Set the IP address of the monitor.

#### SUBNET MASK

Set the gateway mask. Set it to 255.255.255.0 for normal use.

#### DEFAULT GATEWAY

Set the IP address of the gateway router to externally connect the local area including the monitor.

#### RESET

LAN settings are reset.

### ■ MONITOR ID

ID numbers for wireless remote control are assigned to MDT651S monitors that are multi-connected via RS-232C. ID numbers 1 to 26 are selectable.

### ■ OSD TURN OFF

The OSD control menu will stay on as long as it is used. The preset choices are 5 -120 seconds.

### ■ OSD H POSITION

You can adjust the horizontal position of the OSD menu.

### ■ OSD V POSITION

You can adjust the vertical position of the OSD menu.

### ■ OSD ROTATION

The OSD screen is rotated.

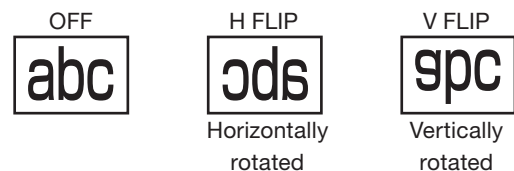

### ■ INFORMATION OSD

You can enable and disable the information OSD display. The display time is selectable from 3 to 10 seconds.

NOTE: The information OSD display shows a message when the input source is switched, the input signal state is changed, or the input signal has an error.

### ■ OFF TIMER

You can select the OFF TIMER mode.

Select the time period to automatically turn off the power from 1 to 24 hours.

NOTE: When OFF TIMER is enabled, the SCHEDULE settings (see page 48) will be disabled.

## OSD screen functions (continued)

---

### ■ SCHEDULE

You can program the LCD monitor operation schedules. (See page 35.)

#### < HOW TO SETUP SCHEDULE >

Using the "SCHEDULE" function allows you to set up to seven different scheduled time intervals when the LCD Monitor will be activated.

You can select the time the monitor turns on and turns off, the day of week the monitor is activated, and which input source the monitor will use for each scheduled activation period. A check mark in the box next to the number of the schedule indicates that the selected schedule is in effect. To select which schedule to set, use the up/down arrows to move the number (1 to 7) of the schedule.

Use the (+) and (-) buttons to move the cursor horizontally within the particular schedule. Use the ▲ and ▼ buttons to increase the time and select the input port. The "SET" button is used to make a selection.

If you create a schedule but do not want to set the power on time, select "--" in the "ON" time slot.

If you do not want to use a power off time select "--" in the "OFF" time slot.

If there is no input selected ("--" showing in the input spot) the input from the previous schedule will be used.

The selection of EVERY DAY within a schedule takes priority over other schedules that are set up to operate weekly.

When schedules are overlapping, scheduled Power ON time has priority over scheduled Power OFF time.

If there are two schedules programmed for the same time, then the highest numbered schedule has priority.

When OFF TIMER is enabled, the "SCHEDULE" settings are disabled.

### ■ DATE AND TIME

You can adjust the current date and time for the internal clock.

You must set this item when using SCHEDULE.

After completing the setting, be sure to press the SET button (button  on page 10).

### ■ MONITOR INFORMATION

The model name and the serial number of your monitor are displayed.

# OSD screen functions (continued)

## ADVANCED OPTION

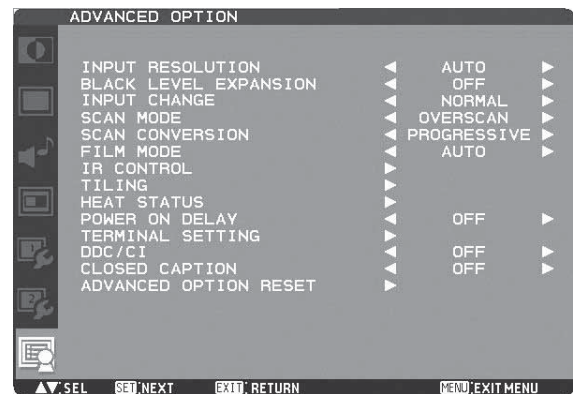

### ■ INPUT RESOLUTION

\* For the RGB3 and RGB4 inputs only.

You can select the following resolutions according to the input signal: AUTO, 1024x768, 1280x768, 1360x768, 1366x768, 1400x1050, 1680x1050, 1600x1200, and 1920x1200. AUTO selects the resolution automatically. The setting you select becomes effective when POWER is turned OFF and ON again.

### ■ BLACK LEVEL EXPANSION

Selects a level of black expansion from "OFF", "MIDDLE" and "HIGH."

In case of go under the black cut-off level, please adjust the "Black level" in moderation on OSD menu.

### ■ INPUT CHANGE

You can select the time for input switching from QUICK and NORMAL.

NOTE: When you select QUICK, slight noise may appear.

### ■ SCAN MODE

\* For the RGB1 (HDMI), DVD/HD, VIDEO<S>, and VIDEO inputs only.

You can select the image display area.

OVERSCAN: About 95% of the input image is displayed.

UNDERSCAN: Almost 100% of the input image is displayed.

### ■ SCAN CONVERSION

\* For the RGB1 (HDMI), DVD/HD, VIDEO<S>, and VIDEO inputs only.

You can select the IP conversion mode.

PROGRESSIVE: Interlace signals are converted into progressive signals. Select this setting for normal cases.

INTERLACE: Interlace signals are displayed without being converted. Though this setting is suitable for motion images, still images aren't displayed properly.

### ■ FILM MODE

You can select the film mode function.

AUTO: Images of 24 frames per second are detected, subjected to interpolation, and then displayed.

OFF: The input video signals are displayed without being subjected to any processing.

NOTE: When FILM MODE is AUTO, set SCAN CONVERSION to PROGRESSIVE. See page 49.

### ■ IR CONTROL

You can lock the wireless remote control.

Select from the following two modes using the ▲ and ▼ buttons and then determine the selected mode by pressing the SET button.

NORMAL: All the remote control operations are enabled.

PRIMARY: The first MDT651S monitor of those multi-connected via RS-232C is designated as PRIMARY.

SECONDARY: MDT651S monitors other than the first one multi-connected via RS-232C are designated as SECONDARY.

LOCK: All the remote control operations are disabled.

NOTE: When you hold down the DISPLAY button on the wireless remote control for at least 5 seconds, the NORMAL mode is activated.

You can lock the wireless remote control independently from the control buttons on the rear of the monitor. See page 51.

### ■ TILING

You can enlarge an image across multiple screens.

A single large screen can be configured with up to 25 monitors. You can also divide the displayed image into up to 5 pieces horizontally and vertically.

NOTE: It is required to connect the same video signal to each monitor via a distributor or RGB OUT.

When TILING is activated, PIP, POP, SBS, and STILL are disabled.

TILING doesn't work in the REAL picture size mode.

H MONITORS: Select the number of images obtained by horizontal division.

V MONITORS: Select the number of images obtained by vertical division.

POSITION: Select the area you want to enlarge.

FRAME COMP.: When displaying an image across multiple monitors, you can select the mode to compensate for the bezel widths for smooth and natural display.

ENABLE: When you select ON, the image in the selected area is enlarged on the screen.

## OSD screen functions (continued)

---

### ■ HEAT STATUS

The statuses of the cooling fan, brightness, and internal temperature are displayed.

NOTE: The cooling fan starts running according to the operating temperature or when COOLING FAN is ON in the SCREEN SAVER menu.

When the operating temperature substantially exceeds the operation guaranteed range, the message "TEMPERATURE WARNING!!" is displayed on the screen.

### ■ POWER ON DELAY

You can adjust the delayed time until the power-on mode is activated at the time of recovery from the sleep mode or power-on.

The time is selectable from OFF and 2, 4, 6, 8, 10, 20, 30, 40, and 50 seconds.

### ■ TERMINAL SETTING

You can select the mode to display the RGB1 (HDMI) or RGB2 (DVI-D) signal according to their signal format depending on their source device.

DVI-MODE:

Select this setting when displaying the RGB2 (DVI-D) signal.

Select DVI-PC when the source device is a PC.

Select DVI-HD when the source device is a video device.

HDMI SIGNAL:

Select this setting when displaying the RGB1 (HDMI) signal.

Select LIMITED when displaying the signal that uses 16 to 235 levels of 256 levels for each of R, G, and B.

Select FULL when displaying the signal that uses all 256 levels (from level 0 to 255).

### ■ DDC/CI

Use to turn ON or OFF the DDC/CI communication function.

Select ON for normal use.

### ■ CLOSED CAPTION

You can select to display or hide captions.

OFF: Captions are hidden.

CC1: Captions are displayed in sync with the primary audio.

CC2: Information (related to the primary audio) is displayed without sync.

CC3: Captions are displayed in sync with the secondary audio.

CC4: Information (related to the secondary audio) is displayed without sync.

TT1/TT2/TT3/TT4: Four types of information not related to the displayed images are displayed. (For example, news and weather forecast.)

NOTE: Check with each supplier of your video software and external video devices in advance whether they are compliant with EIA-608-A.

If their video signals are not compliant with it, images may not be displayed correctly.

### ■ ADVANCED OPTION RESET

Selecting ADVANCED OPTION RESET allows you to reset all OSD settings from ADVANCED OPTION settings, except for DDC/CI.

# Other functions

## Picture size

### RGB1, 2, 3, 4, 5, 6

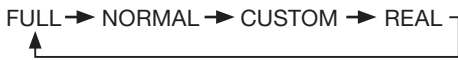

### DVD/HD

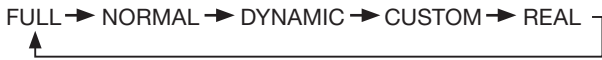

### VIDEO, VIDEO<S>

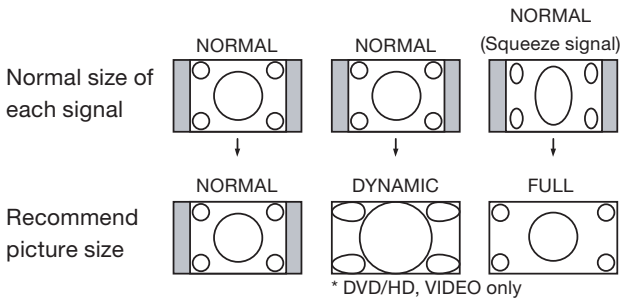
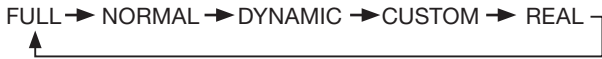

- NORMAL:** Images supplied from external devices such as PC and DVD fit the screen, keeping their original aspect ratio.
- FULL:** Images are displayed on the entire screen.
- DYNAMIC:** 4:3 images are enlarged on the entire screen with non-linearity. (Round images may be cut when enlarged.)
- CUSTOM (ZOOM):** You can enlarge the displayed images beyond the active display area. The portions of the image out of the display area aren't visible.
- REAL:** Images are displayed in their original sizes.

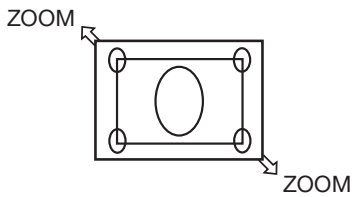

## Picture mode

### RGB1, 2, 3, 4, 5, 6



### DVD/HD, VIDEO, VIDEO<S>

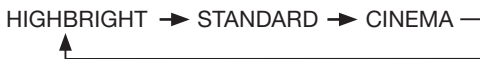

## Audio input change

### RGB1



### Other inputs

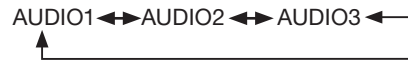

## OSD information

### RGB1, 2, 3, 4, 5, 6

RGB2  
1024 x 768  
48kHz 60Hz  
AUDIO : 1  
SIZE : FULL

- ← Current selection (RGB2)
- ← Resolution  
Horizontal/vertical frequency
- ← Audio input mode
- ← Picture size mode

### DVD/HD

DVD/HD  
AUDIO : 3  
SIZE : FULL

- ← Current selection (DVD/HD)
- ← Audio input mode
- ← Picture size mode

### VIDEO<S>, VIDEO

VIDEO<S>  
NTSC  
AUDIO : 3  
SIZE : NORMAL

- ← Current selection (VIDEO<S>)
- ← Color system mode
- ← Audio input mode
- ← Picture size mode

### PIP, POP

Main : RGB2  
Sub : VIDEO<S>

RGB2  
1024 x 768  
48kHz 60Hz  
AUDIO : 1  
VIDEO<S>  
NTSC  
SIZE : FULL

- ← Main picture information
- ← Audio input mode
- ← Sub picture information
- ← Main picture size

## Control Lock mode

You can lock the operation buttons so that the image adjustments you made aren't changed even when the buttons are pressed.

By holding down both the ▲ and ▼ button on the monitor for 3 seconds or longer, you can lock the operation buttons.

By holding down both the ▲ and ▼ button on the monitor for 3 seconds or longer again, you can unlock the operation buttons.

## Other functions (continued)

### Supplemental information of the auto brightness function

#### To control multiple monitors collectively

In such a case where the tiling function is used, you can control the auto brightness function by sharing the detection result of the brightness sensor of a certain monitor among the connected monitors.

- Multi-connect the monitors using RS-232C or CAT5 cables separately sold as shown by the example below.

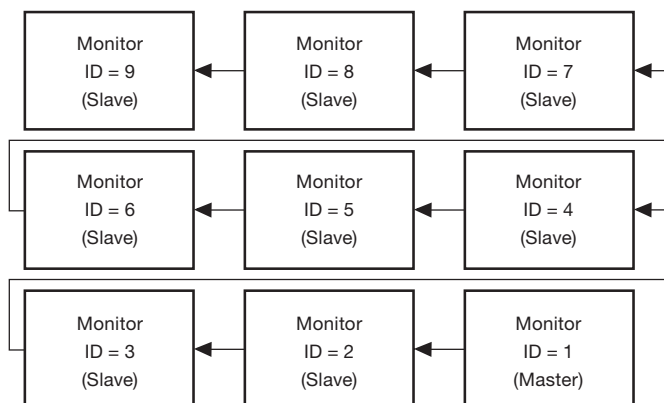

Master: Monitor configured as Master that detects the outside light (Monitor ID is "1".)

Slave: Monitor controlled by the Master monitor (Monitor ID is other than "1".)

- Assign a monitor ID to each multi-connected MDT651S using MONITOR ID. (See page 47.)

Monitor ID is selectable from 1 to 26.

The monitor ID of the Master monitor should be "1" and those of the Slave monitors should be other than "1".

You are recommended to assign IDs to the monitors consecutively from 1, 2, 3, and on.

- Set AUTO BRIGHTNESS on the OSD screen (PICTURE) as follows.

	AUTO BRIGHTNESS	CONTROL
Master monitor	LOCAL	PRIMARY
Slave monitors	REMOTE	SECONDARY

- For connection with CAT5, set [RS485 TERMINATION] of the master monitor and the slave monitor at the end to ON. Set [RS485 TERMINATION] of the other slave monitors to OFF. See page 47.

#### To use a computer to control the monitors

When using a computer to control the monitors, you must prepare an application software program for control by yourself.

- Connect the RS-232C IN connector of the Master monitor shown above and the RS-232C connector of the computer using an RS-232C cable.

Or, using a CAT5 cable, connect the RS-232C connector of the computer to the CAT5 IN connector of the Master monitor via the CAT5 Tx BOX.

- Assign a monitor ID to each multi-connected MDT651S using MONITOR ID. (See step 2 on page 47.)
- Set AUTO BRIGHTNESS on the OSD screen (PICTURE) as follows.

	AUTO BRIGHTNESS	CONTROL
Master monitor	REMOTE	SECONDARY
Slave monitors	REMOTE	SECONDARY

- For connection with CAT5, set [RS485 TERMINATION] of the master monitor and the slave monitors to ON. However, set [RS485 TERMINATION] of the slave monitor at the end to OFF. See page 47.
- For the specifications of the communication commands, contact your dealer.

#### NOTE:

When using CAT5 for control only, you can connect up to 26 monitors. When using the video function together, you are recommended to connect only 5 or less monitors due to the restrictions of the video function. See page 25.



## Other functions (continued)

### PIP, POP function

The following table shows the combinations of signal inputs with which the “PIP” and “POP” modes function. However, these modes do not function when the screen size is “CUSTOM” or “REAL”.

		Sub screen								
		RGB1 (HDMI)	RGB2 (DVI-D)	RGB3 (D-SUB)	RGB4 (BNC)	RGB5 (CAT5)	RGB6 (DISPLAY PORT)	DVD/HD (YPbPr)	VIDEO<S>	VIDEO
Main screen	RGB1 (HDMI)	x	x	x	x	x	x	x	○	○
	RGB2 (DVI-D)	x	x	x	x	x	x	x	○	○
	RGB3 (D-SUB)	x	x	x	x	x	x	x	○	○
	RGB4 (BNC)	x	x	x	x	x	x	x	○	○
	RGB5 (CAT5)	x	x	x	x	x	x	x	○	○
	RGB6 (DISPLAY PORT)	x	x	x	x	x	x	x	○	○
	DVD/HD (YPbPr)	x	x	x	x	x	x	x	○	○
	VIDEO<S>	○	○	○	○	○	○	○	x	x
	VIDEO	○	○	○	○	○	○	○	x	x

○ : Supported    x : Not supported

By pressing the PIP ON/OFF button on the wireless remote control, you can change the PIP, POP, and SIDE BY SIDE modes in the order shown below.

Alternatively, you can change the modes using the PIP MODE setting of PIP in the OSD main menu. See page 45.

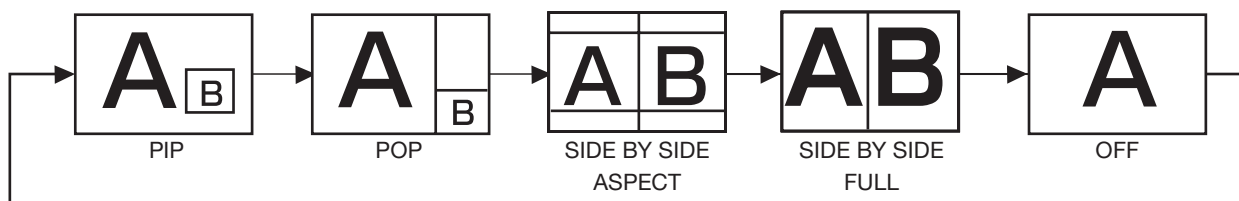

#### [Reference]

The resolutions in the PIP and POP modes are as follows:

PIP SIZE	< SMALL >	: 320 pixels X 240 pixels
	< MIDDLE >	: 480 pixels X 320 pixels
	< LARGE >	: 640 pixels X 480 pixels
POP SIZE		: 450 pixels X 338 pixels

#### NOTE:

Images displayed in the sub picture always fit the PIP sizes shown above irrespective of the aspect ratio of the input image.

## Other functions (continued)

### Remote control numbering function

By connecting multiple MDT651S monitors using RS-232C cables, you can control any one monitor or all the monitors by one remote controller.

1. Assign arbitrary ID number to each of multi-connected MDT651S monitors using MONITOR ID.  
ID numbers 1 to 26 are selectable.  
It is recommended to assign sequential ID numbers from 1 and up.
2. The remote control mode of the first MDT651S monitor is set to PRIMARY and those of the other monitors are set to SECONDARY.
3. When you direct the remote controller at the remote control signal sensor of the PRIMARY monitor and press the DISPLAY button on the remote controller, the ID selection OSD appears at the upper left of the screen.

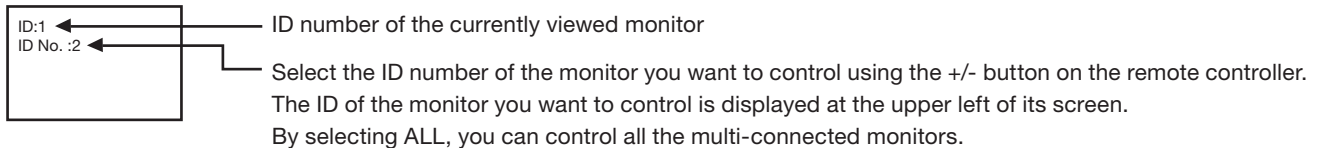

4. Direct the remote controller at the remote control signal sensor of the PRIMARY monitor.  
OSD appears on the monitor having the ID number you selected.

#### NOTE:

When the ID selection OSD is being displayed on the PRIMARY monitor, press the DISPLAY button on the remote controller again to cancel the ID selection OSD and then control the monitor you selected.

If you set the remote control mode wrongly and remote control operation becomes unavailable, press any button on the control panel of the monitor to display the OSD screen and change the remote control mode using ADVANCED OPTION. By pressing and holding down the DISPLAY button on the remote control for 5 seconds or longer, the remote control mode is initialized to NORMAL.

You can perform the same control using CAT5.

# Troubleshooting

---

## No picture

- The signal cable should be securely connected to the display card/computer.
- The display card should be securely seated in its slot.
- The Main Power Switch and the computer power switch should be in the ON position.
- Make sure that the correct mode has been selected on the display card or system being used. (Please consult the display card or system manual to change the graphics mode.)
- Check the monitor and your display card with respect to the compatibility and recommended settings.
- Check the signal cable connectors for bent or pushed-in pins.

## Power button does not respond

- Unplug the power cord of the monitor from the AC outlet to turn off and reset the monitor.

## Image persistence

- Please be aware that LCD Technology may experience a phenomenon known as “image persistence.” Image persistence occurs when a residual or “ghost” image of a previous image remains visible on the screen. Unlike CRT monitors, LCD monitors’ image persistence is not permanent, but constant images being displayed for a long period of time should be avoided. To alleviate image persistence, turn off the monitor for as long as the previous image was displayed. For example, if an image was on the monitor for one hour and a residual image remains, the monitor should be turned off for one hour to erase the image.

### NOTE:

As with all display devices, MITSUBISHI ELECTRIC recommends displaying moving images and using a moving screen saver at regular intervals whenever the screen is idle or turning off the monitor when not in use.

## Image is unstable, unfocused or swimming is apparent

- Signal cable should be securely attached to the computer.
- Use the OSD Image Adjust controls to focus and adjust the display by increasing or decreasing the fine adjustment. When the display mode is changed, the OSD Image Adjust settings may need to be re-adjusted.
- Check the monitor and your display card with respect to the compatibility and recommended signal timings.
- If the displayed text is garbled, change the video mode to the non-interlace mode and use 60 Hz refresh rate.

## Image of component signal is greenish

- Check to see if the DVD/HD input connector is selected.

## LED on the monitor is not lit (No green or red color can be seen)

- Power Switch should be in the ON position and power cord should be connected.
- Make certain the computer is not in the power-saving mode (touch the keyboard or mouse).

## RED LED on the monitor is blinking

- A certain failure may have occurred. Please contact your nearest authorized MITSUBISHI ELECTRIC service facility.

## Displayed image is not sized properly

- Use the OSD Image Adjust controls to increase or decrease the coarse adjustment.
- Make sure that the correct mode has been selected on the display card or system being used. (Please consult the display card or system manual to change the graphics mode.)

## Selected resolution is not displayed properly

- Use OSD Display Mode to enter Information menu and check that the appropriate resolution has been selected. If not, select corresponding option.

## No sound

- Check to see if the speaker cable is properly connected.
- Check to see if the mute is activated.
- Check to see if the volume is set to the minimum level.

## Wireless remote control is not available

- Check the wireless remote control’s batteries status.
- Check if the batteries are inserted correctly.
- Check if the wireless remote control is pointing at the monitor’s remote sensor.

## “SCHEDULE”/“OFF TIMER” function is not working properly

- The “SCHEDULE” function will be disabled when the “OFF TIMER” is set.
- If the “OFF TIMER” function is enabled and the power to the LCD monitor is turned off if the power supply is interrupted unexpectedly, then the “OFF TIMER” will be reset.

Either light vertical or horizontal stripes may appear, depending on the specific display pattern. This is no product fault or degradation.

# Specifications

Orientation		Landscape / Portrait		
Dimension (Unit: mm)				
LCD Module	Screen size (diagonal)	65" (1639 mm)		
	Panel Type	VA		
	Panel Pitch	0.744 mm		
	Resolution	1920 x 1080 pixels (Full HD)		
	Color	Approximately 1.06 Billion		
	Brightness (typ.)	700 cd/m <sup>2</sup>		
	Contrast ratio	2500 : 1		
	Viewing Angle (CR≥10)	Up/Down 178°, Left/Right 178°		
Response time	8 ms (Gray to Gray)			
Viewable Size (H x V)		1428.5 mm x 803.5 mm / 56.2" x 31.6"		
Power Management		VESA DPM		
Plug and Play		VESA DDC2B, DDC/CI		
Auto Adjustment		Yes (Contrast / Position / Phase / Clock)		
OSD user functions		Brightness, Contrast, Black level, Zoom, PIP, Screen saver, Side border color, Gamma selection, Black level expansion, Heat status, Power on delay, Schedule, Tiling, CAT5 control, Auto brightness, Closed Caption, etc.		
Input / Output Signal	PC Input / Output	Input Connector	(Analog)	D-SUB 9-pin, MINI D-SUB 15-pin, BNC (R, G, B, H, V) (PC/AV Common), Modular 8-pin (CAT5)
			(Digital)	HDMI (PC/AV Common), DVI-D (HDCP supported, PC/AV Common), DisplayPort
		Output Connector	D-SUB 9-pin, MINI D-SUB 15-pin (PC/AV Common), Modular 8-pin (CAT5)	
		Horizontal Frequency	15.625/15.734, 31.5 kHz - 91.1 kHz	
		Vertical Frequency	50.0/58.0 Hz - 85.0 Hz	
		Video Signal	Analog: Analog RGB, Digital: TMDS (with HDCP)	
	Sync Signal	Analog: Separate (TTL), Sync on Green, Digital: TMDS		
	Supported Resolution	640 x 480, 800 x 600, 1024 x 768, 1280 x 768, 1360 x 768, 1280 x 1024, 1600 x 1200 (Compressed/Simplified), 1920 x 1080, 1920 x 1200 (Compressed/Simplified)		
	AV Input / Output	Input Connector	(Analog)	Composite <BNC>, Separate (Y/C) <S-TERMINAL>, Component (Y/Pb/Pr) <BNC> (PC/AV Common)
			(Digital)	HDMI (PC/AV Common), DVI-D (HDCP supported, PC/AV Common)
		Output Connector	Analog: Composite <BNC>, MINI D-SUB 15-pin (PC/AV Common)	
	Supported Resolution	Composite/Separate: NTSC, PAL, SECAM, 4.43 NTSC, PAL60 Component/Digital: 480i, 480p, 576i, 576p, 1080i, 720p, 1080p		
	Audio Input / Output	Input Connector	(Analog)	RCA pin-jack L/R x 2, Stereo mini jack
		(Digital)	HDMI (digital audio)	
	Output Connector	RCA pin-jack		
	Speaker Output	External Speaker Terminal (L/R), 7W + 7W (8 ohm)		
Control Input / Output	Input Connector	RS-232C <D-SUB 9-pin>, CAT5 <Modular 8-pin> (PC/Control Common), LAN <Modular 8-pin>		
	Output Connector	RS-232C <D-SUB 9-pin>, CAT5 <Modular 8-pin> (PC/Control Common)		
Power Supply	Input Voltage / Current	4.9 A - 2.0 A @AC100 - 240 V, 50/60 Hz		
	Power Consumption	487 W (460 W without speaker)		
	Power Consumption at Power Saving	Less than 2 W (less than 5 W with CAT5 input select), Mechanical Power SW off: 0 W		
Operation Environment	Temperature	5 - 40°C / 41 - 104°F (Landscape Mode), 5 - 35°C / 41 - 95°F (Portrait Mode)		
	Humidity	20 - 80% (without condensation)		
Storage Environment	Temperature	-20 - 60°C / -4 - 140°F		
Humidity	10 - 90% (Without condensation) / 90%-3.5% x (Temp-40 °C) regarding over 40 °C			
Dimension (W x H x D)	Net (without stand)	1498 mm (W) x 873 mm (H) x 139 mm (D) / 59.0" (W) x 34.4" (H) x 5.5" (D)		
	Gross	1774 mm (W) x 1200 mm (H) x 375 mm (D) / 69.8" (W) x 47.2" (H) x 14.8" (D)		
Weight	Net (without stand)	Approximately 46.5 kg / 102.5 lbs		
	Gross	Approximately 62.4 kg / 137.6 lbs		
Wall mounting interface		8-M8 Screws holes (200 mm / 7.9" pitches) for Monitor mount		
Complied regulatory and guidelines*1		UL60950-1 / C-UL / EN60950-1 / CE / BSMI / GOST-R / FCC-B / DOC-B / EN55022-A / EN55024 / EN61000-3-2 / EN61000-3-3 / C-Tick / RoHS / US Mercury		

\*1: These regulatory and guidelines do NOT apply in Japan.

これらの規格およびガイドラインは日本国内用ではありません。

**NOTE:** Technical specifications are subject to change without notice.

# Pin Assignment

## 1) Analog RGB input (Mini D-SUB 15-pin): RGB3

Pin No	Name	Pin No	Name
1	Video Signal Red	9	+5V (DDC)
2	Video Signal Green	10	SYNC-GND
3	Video Signal Blue	11	GND
4	GND	12	DDC-SDA
5	DDC-GND	13	H-SYNC
6	Red-GND	14	V-SYNC
7	Green-GND	15	DDC-SCL
8	Blue-GND		

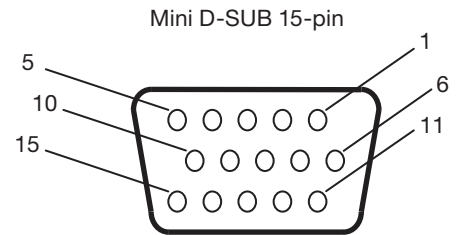

## 2) Analog RGB input (CAT5): RGB5

Pin# at RJ45	Signal	Pair
#1	Red Video+	[ ]
#2	Red Video-	
#3	Green Video+	[ ]
#4	Blue Video+	
#5	Blue Video-	[ ]
#6	Green Video-	
#7	RS-485+	[ ]
#8	RS-485-	

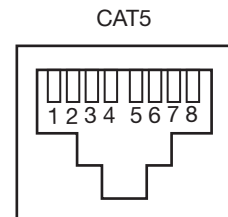

## 3) Digital RGB input (HDMI): RGB1

Pin - Assignment of HDMI connector:					
1	TMDS Data2+	8	TMDS Data0 Shield	15	SCL
2	TMDS Data2 Shield	9	TMDS Data0-	16	SDA
3	TMDS Data2-	10	TMDS Clock+	17	DDC/CEC Ground
4	TMDS Data1+	11	TMDS Clock Shield	18	+5V Power
5	TMDS Data1 Shield	12	TMDS Clock-	19	Hot Plug Detect
6	TMDS Data1-	13	CEC		
7	TMDS Data0+	14	Reserved (N.C. on device)		

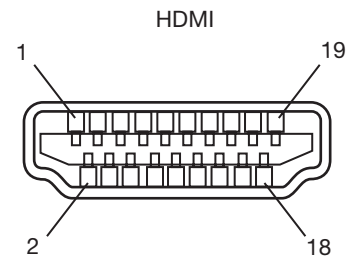

## 4) Digital RGB input (DVI-D): RGB2

Pin - Assignment of DVI-D connector:					
1	TMDS Data2-	9	TMDS Data1-	17	TMDS Data0-
2	TMDS Data2+	10	TMDS Data1+	18	TMDS Data0+
3	TMDS Data2 Shield	11	TMDS Data1 Shield	19	TMDS Data0 Shield
4	NC	12	NC	20	NC
5	NC	13	NC	21	NC
6	DDC Clock	14	+5V Power	22	TMDS Clock Shield
7	DDC Data	15	Ground (return for +5V, H-SYNC and V-SYNC)	23	TMDS Clock+
8	Analog Vertical Sync	16	Hot Plug Detect	24	TMDS Clock-

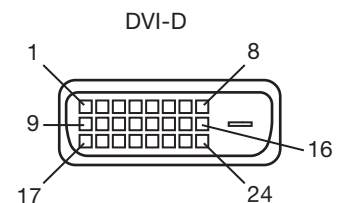

## Pin Assignment (continued)

### 5) Digital RGB input (DISPLAY PORT): RGB6

Pin No	Name	Pin No	Name
1	ML_Lane 3 (n)	11	GND Top
2	GND	12	ML_Lane 0 (p)
3	ML_Lane 3 (p)	13	CONFIG1
4	ML_Lane 2 (n)	14	CONFIG2
5	GND	15	AUX CH (p)
6	ML_Lane 2 (p)	16	GND
7	ML_Lane 1 (n)	17	AUX CH (n)
8	GND	18	Hot Plug Detect
9	ML_Lane 1 (p)	19	Return
10	ML_Lane 0 (n)	20	DP_PWR

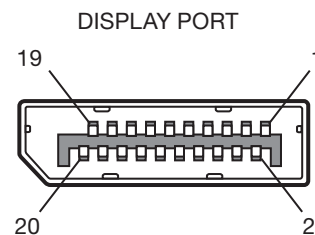

### 6) S-VIDEO input (MINI DIN 4-pin): VIDEO<S>

Pin No	Name
1	GND
2	GND
3	Y (Luminance)
4	C (Chroma)

MINI DIN 4-pin

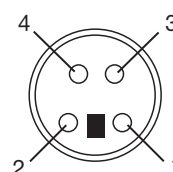

### 7) RS-232C input/output

Pin No	Name
1	NC
2	RXD
3	TXD
4	NC
5	GND
6	NC
7	NC
8	NC
9	NC

D-SUB 9-pin

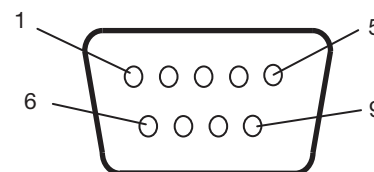

### 8) LAN (Modular 8-pin)

Pin# at RJ45	Signal	Pair
#1	Orange/White stripe	□
#2	Orange	
#3	Green/White stripe	□
#4	Blue	
#5	Blue/White stripe	□
#6	Green	
#7	Brown/White stripe	□
#8	Brown	

Modular 8-pin

